

# D-series Flow Monitor

## Manual



## Contents

<b>D-series Flow Monitor</b> .....	<b>1</b>
<b>Manual</b> .....	<b>1</b>
<b>Contents</b> .....	<b>2</b>
<b>About this Manual</b> .....	<b>4</b>
<b>Proprietary Rights</b> .....	<b>4</b>
<b>Distributors</b> .....	<b>4</b>
<b>Customer Service</b> .....	<b>4</b>
<b>1 General Information</b> .....	<b>5</b>
1.1 Description _____	5
1.2 Overview Control Unit _____	6
1.3 Overview Pipe Section _____	6
1.4 Pipe Dimensions _____	7
1.5 PED Certification _____	7
1.6 EMC _____	7
1.7 Type Plate _____	8
1.8 Specifications _____	9
<b>2 Installation</b> .....	<b>10</b>
2.1 Unpacking _____	10
2.2 Preparations _____	10
2.3 Installation of the Flow Monitor _____	11
2.4 Installation and Changing of the Control Unit _____	14
2.5 Separate Mounting of the Control Unit and Pipe Section _____	15
2.5.1 Separate Mounting - Installation _____	16
2.6 Electrical Installation _____	17
2.7 HART Protocol Specification _____	18
2.7.1 HART protocol point-to-point mode _____	18
2.7.2 HART Identifying Device _____	19
2.8 Zero based / Non-Zero based Calibration _____	20
2.8.1 Zero-Based Signal _____	20
2.8.2 Non-Zero-Based Signal _____	20

<b>3 Operation.....</b>	<b>22</b>
3.1 Display Settings _____	22
3.1.1 Overview _____	22
3.1.2 Language _____	23
3.1.3 Settings _____	23
3.1.4 Options _____	26
3.1.5 Simulation _____	28
3.1.6 Info _____	28
3.1.7 Factory Default _____	29
3.1.8 Calibrate _____	31
3.2 Change of Flow Direction _____	32
3.3 Change of Flow Range _____	33
<b>4 Differential Pressure Measurement.....</b>	<b>35</b>
4.1 The Differential Pressure Principle _____	35
4.2 Pressure Drop _____	35
<b>5 Trouble Shooting.....</b>	<b>37</b>
5.1 Inaccurate Flow Prediction _____	37
5.2 Spares _____	37
<b>6 Spare Parts.....</b>	<b>38</b>
6.1 BOM Drawing D-GL/FA _____	38
6.2 BOM Drawing D-GSS/FSS _____	40
6.3 BOM Drawing D-SS GSS/FSS _____	42
<b>7 Weight and dimensions.....</b>	<b>44</b>
<b>8 Measuring Ranges .....</b>	<b>45</b>
<b>9 Recycling.....</b>	<b>46</b>

## About this Manual

- This manual relates to the D-series Flow Monitor.
- Note that the latest version of this manual is always available as a PDF file on our web site [www.eletta.com](http://www.eletta.com)
- On our web site you also find other interesting information such as leaflets, newsletters and application reports.

## Proprietary Rights

This manual contains confidential technical data, including trade secrets and proprietary information, that are the property of Eletta Flow AB, Sweden.

Any changes or alterations to downloaded or printed Eletta original documentation such as manuals, drawings, leaflets, newsletters, etc. are not permitted without a written permission from Eletta Flow AB, Sweden.

These data are only disclosed to you under permission of limited use within your company. Use for manufacturing or processing is not permitted.

Any other use of data and information is strictly prohibited without prior written permission from Eletta Flow AB, Sweden.

## Distributors

Eletta has appointed a number of distributors all over the world. You will find more information about your closest distributor at our web site [www.eletta.com](http://www.eletta.com), or by contacting our Customer Service Center.

## Customer Service

Phone           +46 8 603 07 70 Switchboard  
                  +46 8 603 07 80 Orders and Inquires

Postal Mail    Eletta Flow AB  
                  P.O. Box 5084  
                  SE-141 05 Kungens Kurva  
                  SWEDEN

E-mail           info@eletta.com  
Web             www.eletta.com

## 1 General Information

### 1.1 Description

The D-series Eletta Flow Monitor are used to measure and control flows of liquids and gases in threaded pipes with sizes DN15-DN40 and flange fitted pipe sizes DN15 to DN500.

The Eletta Flow Monitor is based on the proven and dependable differential pressure principle, using interchangeable orifice plates for different measuring ranges. The Flow Monitors are working with three different differential pressure ranges, i.e. 127-510 mmH<sub>2</sub>O (12,5-50 mbar) for the D2-LP, 500-2000 mmH<sub>2</sub>O (49-196 mbar) for the D2 and 220-5500 mmH<sub>2</sub>O (22-539 mbar) for the D5, depending on the desired and ordered flow range and the same goes for our models; V1 and V15, S2 and S25 and R2 and R5. Due to the working principle of the instrument, it is of utmost importance that the installation instructions are followed carefully in order to get the proper function of the instrument.

The Instrument mainly consists of two parts i.e. the Pipe Section and the Control Unit. The Pipe Section is the part that is to be mounted in the process pipe and the Control Unit is mounted directly (standard) or remote on/to the Pipe Section.

D-series is available with four different types of pipes; Threaded GL/GSS and FA/FSS for flanged fitting.



**D-GL**



**D-GSS**



**D-FA**



**D-FSS**

*Image 1*

## 1.2 Overview Control Unit

The Control Unit mainly contains the diaphragm housing and two circuit boards (the display circuit board and the power circuit board). The mechanical movement on the diaphragm lever created by the differential pressure in the pipe is acting on the rubber diaphragm in the same way as our other mechanical Flow Monitors. The lever connected to the diaphragm is acting on a linear potentiometer placed on the power circuit board in the Control Unit. As our Monitors have a linear function between the differential pressure and the flow, the circuit board will give you a linear flow output of 4-20 mA, HART protocol, pulse or 200-1000 Hz frequency. The difference to our mechanical V and S-series is that in the D-series there is no mechanical linkage acting on micro switches, as the unit lacks them, only the potentiometer giving information to the circuit board. Since there are fewer moving parts and less mechanical linkage in the Control Unit, the D-series will give you a higher accuracy than V and S-series.

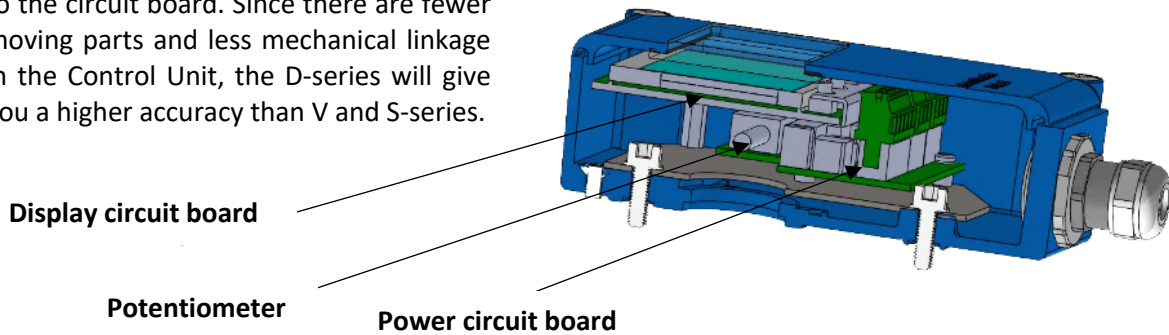

Image 2

In order to get the unit to work properly with good accuracy, it is very important that the unit is installed correctly according to the installation instruction, see chapter 2 "Installation".

## 1.3 Overview Pipe Section

The Pipe Section is assembled in-line with the process pipe and the Control Unit is fitted on top of the Pipe Section. It is also possible, for example when measuring a too hot media, to install the Control Unit separated (using either steel pipes or tubes) from the Pipe Section, see chapter 2.5.

There are four different types of Pipe Sections; GL, GSS, FA and FSS. All Pipe Sections contains an exchangeable Orifice Plate.

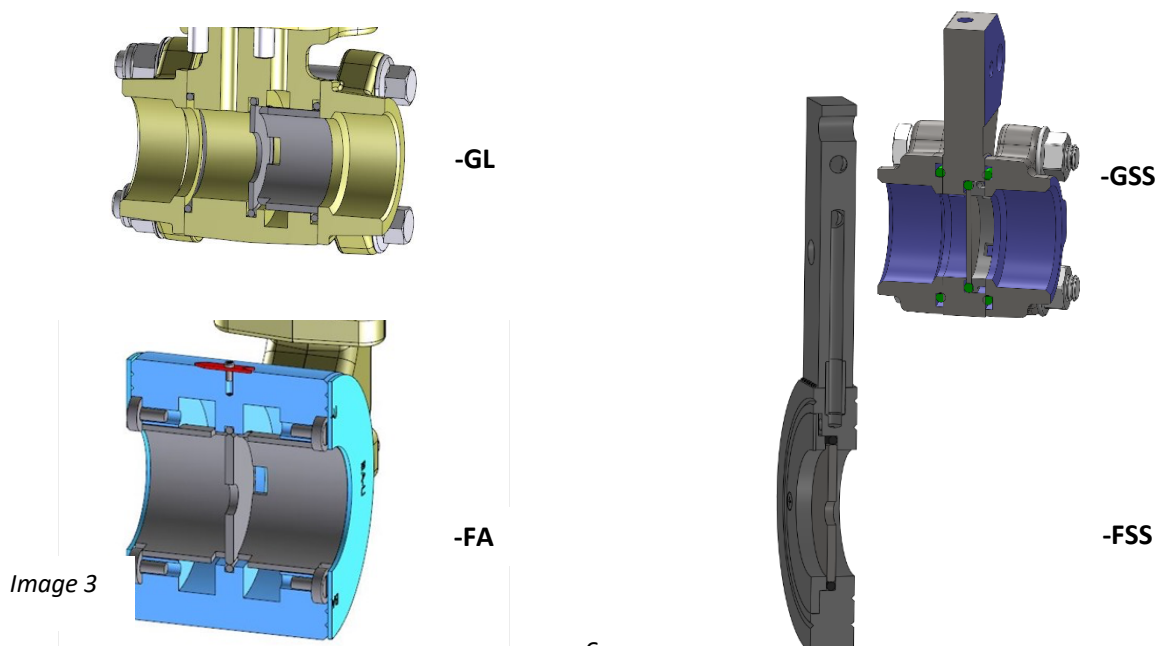

Image 3

## 1.4 Pipe Dimensions

The Pipe Sections are available in various dimensions and materials to fit different requirements of various applications. Following tables provide a summary of our different materials and fittings.

Threaded connections		
Pipe material	Type	Available dimensions
Dezincified Brass, CW602N/EN12420	GL15 - GL40	DN15 - DN40, ½ - 1½" BSP DN15 - DN40, ½ - 1½" NPT
Stainless Steel 316L	GSS15 - GSS25	DN15 - DN25, ½ - 1" BSP DN15 - DN25, ½ - 1" NPT

Flange connections		
Pipe material	Type	Available dimensions
Powder coated (2022009697096) steel, 1.0060/E335/SS1650.	FA15 - FA400	DN15 - DN400, DIN PN16 DN15 - DN100, ANSI 150 lbs DN125 - DN200, Suitable ANSI 150 lbs DN250 - DN300, ANSI 150 lbs
Stainless Steel 316L	FSS15 - FSS500	DN15 - DN500, DIN PN16 DN15 - DN500, ANSI 150 lbs
Stainless Steel 254SMO/EN1.4547 *	FSS15 - FSS500	DN15 - DN500, DIN PN16 DN15 - DN500, ANSI 150 lbs
Bronze CC491K/493K-GC/GZ/1982 *	Option FA15 - FA400	DN15 - DN400, DIN PN16 DN50 - DN100, ANSI 150lbs DN125 - DN200, Suitable ANSI 150 lbs DN250 - DN300, ANSI 150 lbs

\* Optional material for given types and dimensions.

## 1.5 PED Certification

Complies with applicable parts in Pressure Equipment Directive 2014/68/EU. Conformity assessment has been performed according to module A. Internal production control combined with module A2. Internal manufacturing checks with monitoring of the final assessment, for category 2. Performed by Kiwa Inspecta AB. PED Declaration of conformity will be sent to you upon request and are also available on [www.eletta.com](http://www.eletta.com).

## 1.6 EMC

D-series Flow Monitor comply with the EMC directive 2014/30/EU and Electromagnetic Compatibility Regulations 2016 according to report no. 622-20134-10-RO.

## 1.7 Type Plate

Each Eletta Flow Monitor wear a Type Plate with technical data and specifications for the specific Flow Monitor. The Type Plate is located on the top of the Control Unit shown as below.

Always check that the information on the Type Plate corresponds to what you have ordered.

The Type Plate states the following:

- **Type:** Model type of the Flow Monitor.  
For example: D5-GL15.
- **Range:** Flow range of which the Flow Monitor has been manufactured.  
i.e. what the Orifice Bore has been calculated for.
- **Liquid:** The media of which the Flow Monitor has been manufactured.  
For example: Water, Oil, Air, etc.
- **Model:** The article number of the Flow Monitor.
- **No:** The serial number of the Flow Monitor.
- **Temp:** The operating temperature range allowed for the Flow Monitor.
- **Max Pressure:** The maximum operating pressure allowed for the Flow Monitor.
- **Protection Class:** IP-classification of the Flow Monitor (International Protection Marking).
- **Std:** Pipe standard of the Pipe Section.  
For example: DIN PN16/ANSI, BSP/NTP.
- UKCA - CE marking and year of manufacturing.

<b>ELETTA</b>		Phone +46 (0)8 6030770 www.eletta.com
ELETTA FLOW AB, SE-14105 KUNGENS KURVA, SWEDEN		
Type:		Temp:
Range:		Max Pressure:
Liquid:		Protection Class:
Model:		Std:
No:		<b>CE UK CA</b>

Fig. 1



## 1.8 Specifications

<b>Flow range</b>	Liquids: 0,4-25 000 l/min, depending on pipe size See chapter 8 “Measuring Ranges” for a table of our standard flow ranges for water and oil Gases: will be calculated according to application
<b>Flow measuring range (Turn Down)</b>	D2-model: TD of 1:2 (50-100% Flow Range) D5-model: TD of 1:5 (20-100% Flow Range)
<b>Accuracy</b>	±2% F.S. (Full scale). For LP Low pressure version ±5%. Accuracy is stated as per reference and under ideal conditions i.e. straight runs, temperature, pressure, viscosity and density. It is recommended that you always chose the flow range of the Flow Monitor so that the normal process flow is in the middle of the Monitor Flow Range. For example: If you have a flow of 110 l/min maximum and the normal flow is at 90 l/min, choose the Eletta Flow Monitor D2 with a flow range of 60 - 120 l/min. This will give you the highest accuracy since your flow is in the middle of the Monitor Flow Range and will also give you a lower pressure loss
<b>Pressure</b>	Pressure class: PN16 / ANSI 150 lbs Max static pressure: 16 bar (232 PSI) Min static pressure: Line pressure of approximately 1 bar (14 PSI) is required for proper operation, for LP version 0,5 bar.
<b>Protection class</b>	IP65 (NEMA4)
<b>Temperature ranges</b>	<b>Control unit</b> Operating temp: -10 to 65°C (14 to 149°F) Higher process temperatures are achievable by remote installation of the Control unit, see chapter 2.5 “Separate Mounting” <b>Pipe section</b> GL and FA: -10 to 120°C (14 to 248°F) GSS and FSS: -10 to 250°C (14 to 482°F)
<b>Power supply</b>	DC 19-28 V Nominal 24 V
<b>Output</b>	4-20 mA, HART protocol, pulse or 200-1000 Hz frequency (AO update rate 20 ms) See chapter 2.6 “Electrical Installation”
<b>Connection cable</b>	Shielded twisted pair, min. 0,2 mm <sup>2</sup> (0,0031 inch <sup>2</sup> )
<b>Current consumption</b>	Max 100 mA
<b>Alarm relays</b>	Two independent relays, user-settable over the entire flow range. <ul style="list-style-type: none"> <li>• <b>Resistive Load:</b> <ul style="list-style-type: none"> <li>○ 0.5 A at 125 VAC</li> <li>○ 1 A at 24 VDC</li> </ul> </li> <li>• <b>Inductive Load</b> <ul style="list-style-type: none"> <li>○ 0.3 A at 125 VAC</li> <li>○ 0.5 A at 24 VDC</li> </ul> </li> <li>• <b>Minimum Switching Load:</b> 10 µA at 10 mVDC</li> </ul>
<b>Materials: Diaphragm, O-rings and sealings</b>	NBR (Nitrile rubber), standard for GL/FA, optional on GSS/FSS FPM (Fluorinated rubber), standard on GSS/FSS, optional on GL/FA EPDM (Ethylene Propylene Diene), optional on all models
<b>Materials: Spacers</b>	GL pipes: Polyamide plastic (-10 to 120°C /14 to 248°F) FA pipes: DN15-100 Polyamide plastic (-10 to 120°C /14 to 248°F) DN125 – 400 Stainless steel EN 1.4404 (ASTM 316L)

## 2 Installation

### 2.1 Unpacking

Before installation, we kindly ask you to perform the following steps:

1) Check that there are no external damages to the outer packaging. If there are damages, check to see if the Flow Monitor has been damaged. If there is a transportation damage on the Flow Monitor, please contact your forwarder.

2) Check that the delivered parts correspond to the Packing list. Also check that the information on the Type Plate corresponds to what you have ordered. The Type Plate is located on top of the Control Unit, see chapter 1.7 “Type Plate”.

The packaging material is made of recycled environmental friendly material, and we kindly ask you to deal with the material in a way that will have as little impact on the environment as possible.

### 2.2 Preparations

Before installation, we kindly ask you to perform the following steps:

1) Eletta recommends that you choose a correct position for installation of the Flow Monitor in your pipe system. The following table serves as a guideline.

Process Media	Correct installation
Liquid	Low level position of the system
Gas	High level position of the system

2) Check that the planned flow direction in your pipe system corresponds to the flow direction of the Flow Monitor. The flow direction is indicated by a red arrow that is mounted on the Pipe Section. If there is a mismatch of the flow direction, we refer to chapter 3.2 “Change of Flow Direction” for instructions on how to adjust the internal flow direction selector (GL/FA), and how to use the flow direction change block (GSS/FSS) to match the desired flow direction.



### 2.3 Installation of the Flow Monitor

**Note! Before starting the installation, please make sure that the piping is not pressurized from liquid or gas!**

The Flow Monitor can be installed vertically or horizontally. We do not recommend to install the Flow Monitor upside down, this is to prevent particles in the fluid to collect in the diaphragm housing. Please use a filter in the pipe line if you suspect the fluid to contain particles. Below you can see the display orientations available, the display orientation will be pre-configured according to the orientation code (A/R, B/L, C/R, etc.) that was specified upon ordering the Flow Monitor.

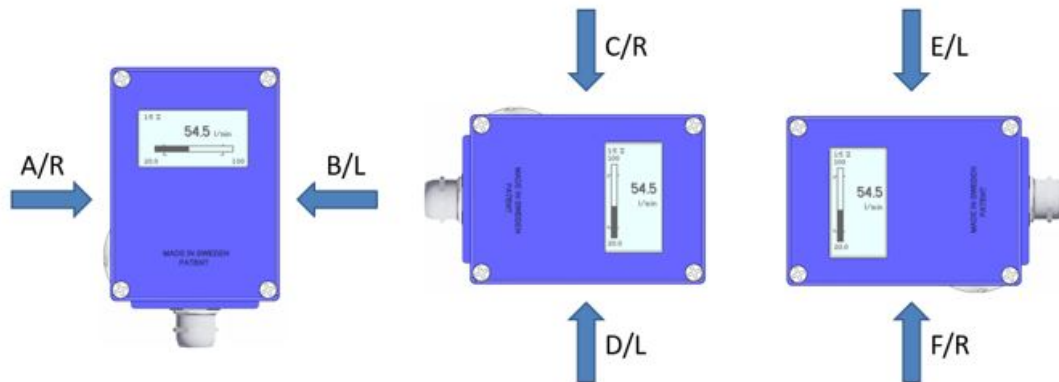

It is very important that the Flow Monitor is mounted in the correct flow direction as the function of the Flow Monitor otherwise will be prevented. The flow direction arrow that is located on the Pipe Section denotes the flow direction which needs to correspond with the flow direction in the system.

The piping shall be rigid and vibration free. Hoses connected directly into the Flow Monitor should be avoided as much as possible. On the rear side of the GL Pipe Section there is a threaded M6 hole which can be used to secure the Flow Monitor on a wall or similar by using an angle bracket. For FA and FSS Pipe Sections you can support the Flow Monitor by using rigid brackets. We recommend installing the brackets both downstream and upstream to avoid unnecessary stress in the installation area.

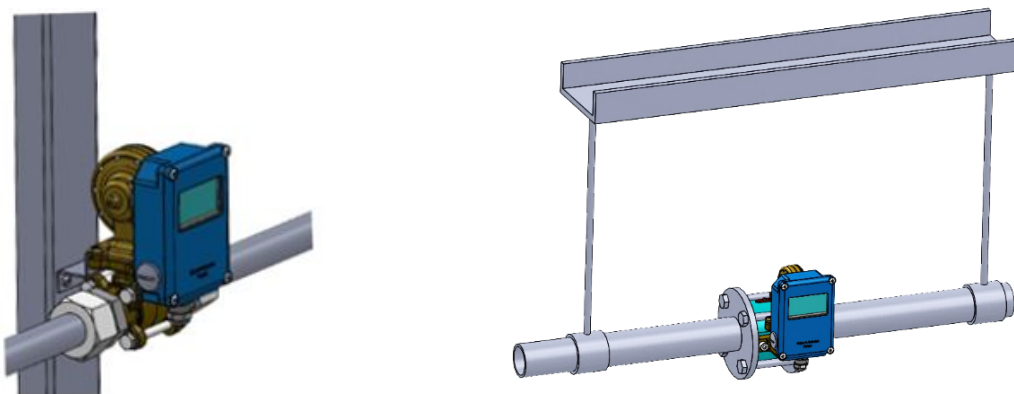

If your piping system still suffers from vibrations, we recommend a separate mounting of the Pipe Section and Control Unit. See chapter 2.5.

### Installation of pipes with threaded flanges

In the case that the inner diameter of your pipes, including fittings, does not correspond to the inside diameter of our pipes, inaccuracy may occur. Fittings with an inside diameter that is smaller than the inside diameter of the Eletta Pipe Section may create a media jet stream of the media, this will result in a too low differential pressure and thereby causing a measurement error. See chapter 7 “Dimension Tables” for inside and outside diameters of our different pipes.

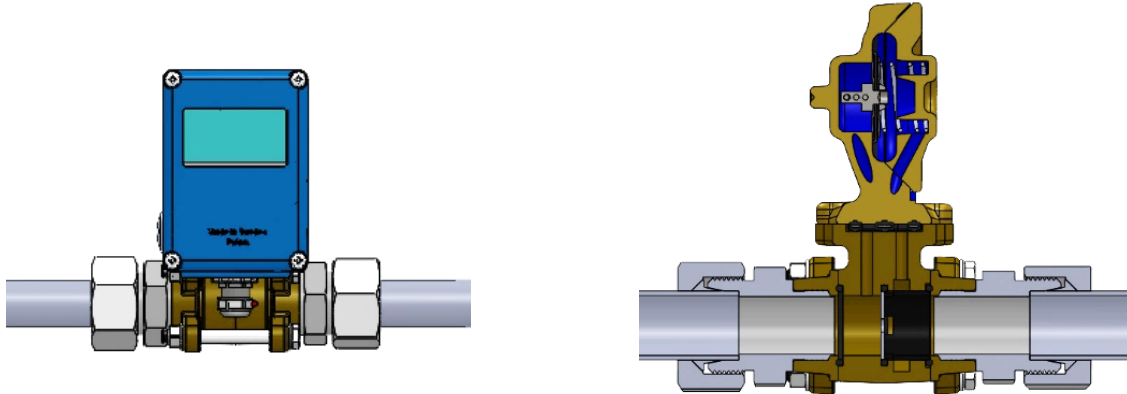

Fig. 4

### Installation of pipes for flanged fittings

FA and FSS-versions must be aligned with the counter flanges and should not be exposed to stress related to unevenly tightened bolts. The flanged models are delivered with two fiber gaskets which we recommend that you use since they are dimensioned according to our pipe dimensions. Please ensure that the gaskets are properly aligned and do not obstruct the flow.

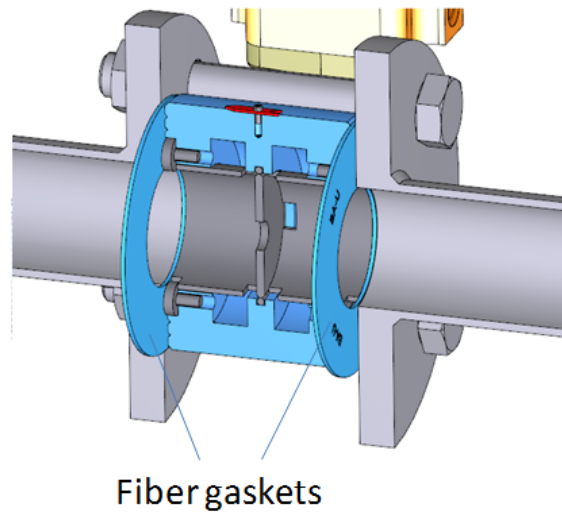

Fig. 5

### **Straight runs**

To obtain maximum accuracy, make sure that the system pipe has sufficiently long straight runs before and after the installed Flow Monitor.

We recommend the straight runs to be at least 10-15 times the pipe diameter upstream and 5 times the pipe diameter downstream.

Also make sure that there are no valves, bends or diameter changes, this is to avoid flow disturbances which might cause an inaccurate reading of the flow.

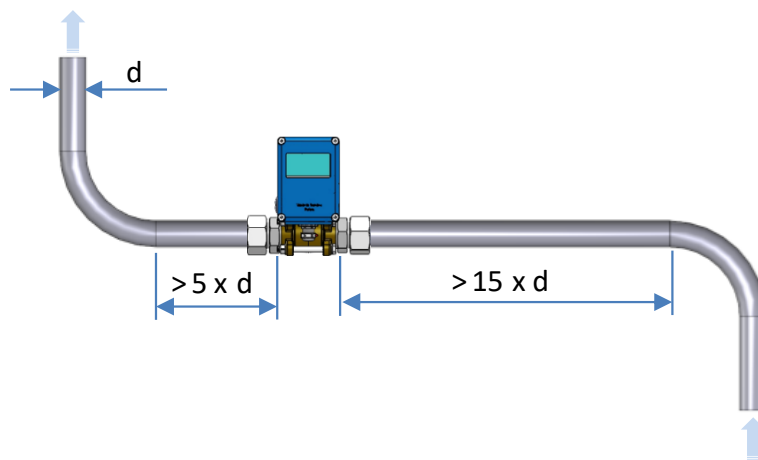

*Fig. 6*

### **Note!**

In applications where maximum accuracy is not necessary, the lengths of the runs can be reduced. Note that it is practically impossible to predict where and when a flow gets stable after a disturbance. Therefore, the recommendation above serves only as a guideline, i.e. a method that has proven to secure the measurement accuracy. If shorter runs are used, Eletta neither can guarantee the specified maximum accuracy, nor predict the flow in your specific application.

## 2.4 Installation and Changing of the Control Unit

All Eletta Flow Monitors are designed to achieve a modular and versatile instrument. The modular system allows you to upgrade, rebuild or add other features to your already installed Flow Monitor.

For example: if you would like to upgrade a V or S-series with mechanical micro switches to a D-series including user settable relay switches and a mA, pulse or frequency output this is easily done. Simply order a new D-series Control Unit to replace your old Control Unit and keep your existing Pipe Section and orifice.

You will get the Control Unit with the diaphragm housing included. Make sure you order the right material in the diaphragm housing and the soft rubber parts (diaphragm, O-rings and lever) and you will get the Control Unit already tested and calibrated and ready to fit onto the Pipe Section, without any on-site adjustments or re-calibration. All Eletta DP Flow Monitors work with the same differential pressure within their specific range, see chapter 4.2 “Pressure Drop”.

**As an option we also have a manifold with shut-off valves for versions GL/FA and GSS/FSS. The manifold is installed between the Control Unit and the Pipe Section, this enables you to dismantle the Control Unit from the Pipe Section during full operation. If you do not have a manifold installed, you need to shut off your system and make sure that the piping is not pressurized before changing the Control Unit.**

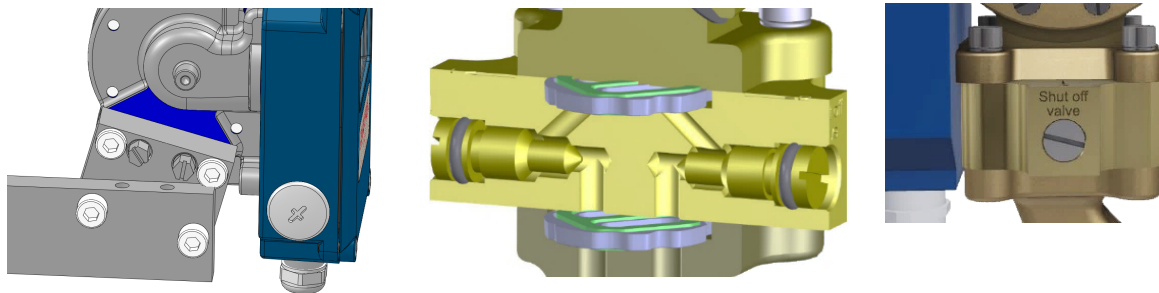

Fig. 7

### Note!

Before you start, make sure that the piping system is not pressurized or shut the shut-off valves if you have a manifold installed. Turn the electric power supply off and then disconnect the cables from the electric terminal.

### On GL/FA Pipe Section

Loosen the four (4) hexagon screws that hold the diaphragm housing to the Pipe Section. **Do not remove the blue housing from the diaphragm housing at any time!** Replace the flow direction selector if damaged (available as a spare part). Install the new Control Unit and tighten the four (4) hexagon screws firmly again.

### On GSS/FSS Pipe Section

Loosen the two (2) hexagon screws that hold the diaphragm housing to the Pipe Section. **Do not remove the blue housing from the diaphragm housing at any time!** Replace the O-rings if damaged (Spares included with your new Control Unit). Install the new Control Unit and tighten the two (2) screws firmly again.

## 2.5 Separate Mounting of the Control Unit and Pipe Section

Sometimes, the pipe Section and the Control Unit need to be separately located from each other. The reasons could be lack of space, high system media temperature or vibrations. As the Eletta Flow Monitor is using the differential pressure caused by the orifice plate mounted in the pipe section and directs these two pressures via two individual ports up to the control Unit, it is possible to separate the Monitor from the Pipe Section into two parts.

When installing the Pipe Section and the Control Unit separately, these channels are extended by using two plastic hoses. These hoses are fitted between the Pipe Section and the Control Unit using two adapters.

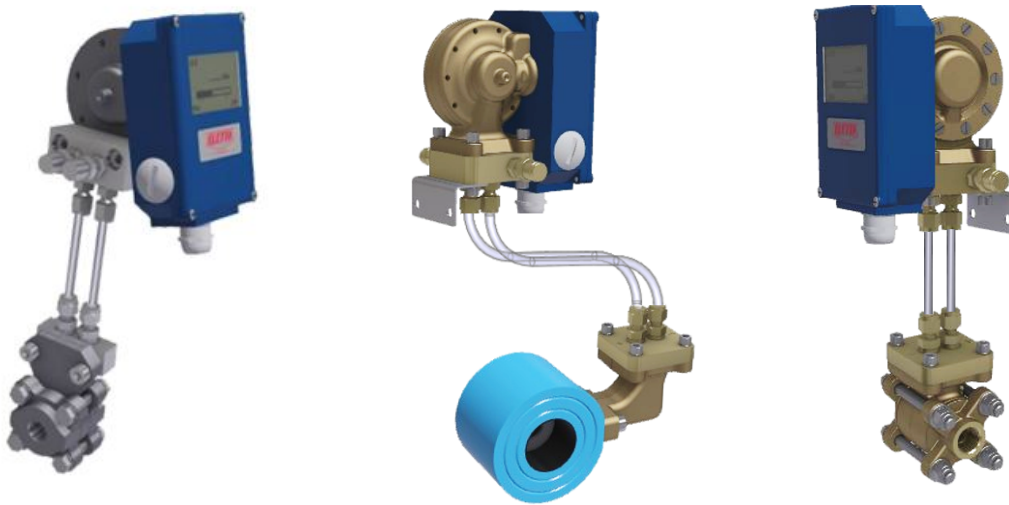

Image 5

As a standard, two 1,75 m (5.74 feet) PA plastic hoses are delivered with the Separate Mounting kit. The diameter is 6 mm (0,23 inch) and suitable for a maximum temperature of 90 °C (194 °F) and a maximum pressure of 16 bar (232 PSI).

The plastic hoses shall not be used for temperatures higher than 90 °C (194 °F) or pressures higher than 16 bar (232 PSI). If your process temperature or pressure exceeds these levels, we recommend you to use copper or stainless steel pipes. Such pipes are not included with the product. Choose material with respect to the type of liquid or gas in your system. If you are using a chemical reactive media, check with your tubing supplier which is the most suitable material to use for your application.

For a Separate Mounting you need two different adapters. One that is installed on the Pipe Section and one for the Control Unit. The Control Unit adapter has valves for discharging entrapped air in the tubes. There is also an angle bracket included for wall fitting.

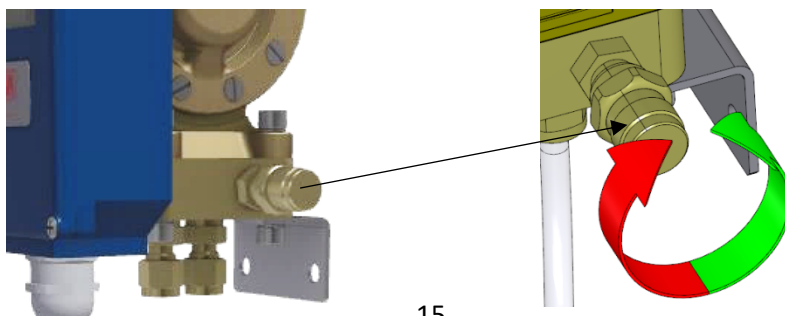

Fig. 8

### 2.5.1 Separate Mounting - Installation

We recommend installing the Pipe Section and the Control Unit as close to each other as practically possible. This will facilitate future trouble-shooting and on-site calibration.

Assemble the Control Unit adapter to the Control Unit (see chapter 2.4 on how to separate Control Unit and Pipe Section). If Separate Mounting is ordered together with the Control Unit and Pipe Section, the adapter will be assembled from factory.

Find a suitable place for installing the Control Unit. We recommend that the Control Unit is installed where it is easily accessed with respect to maintenance.

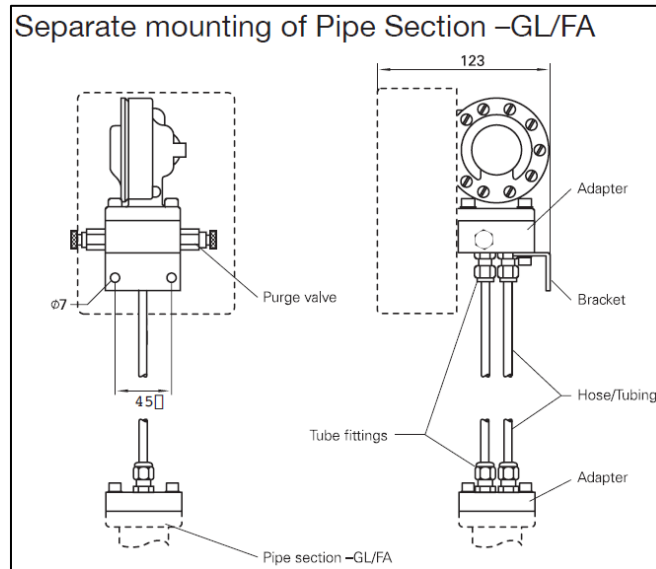

Fig. 9

Assemble the Pipe Section adapter to the Pipe Section (see chapter 2.4 on how to separate Control Unit and Pipe Section). If Separate Mounting is ordered together with the Control Unit and Pipe Section, the adapter will be assembled from factory.

Install the Pipe Section according to the instruction in chapter 2.3. In this case you can mount the Pipe Section in any direction, vertically or horizontally, and with the pressure channels pointing upwards, downwards or sideways.

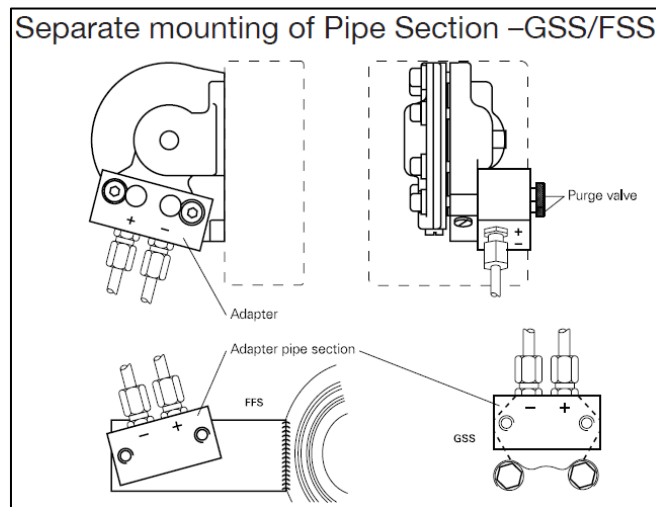
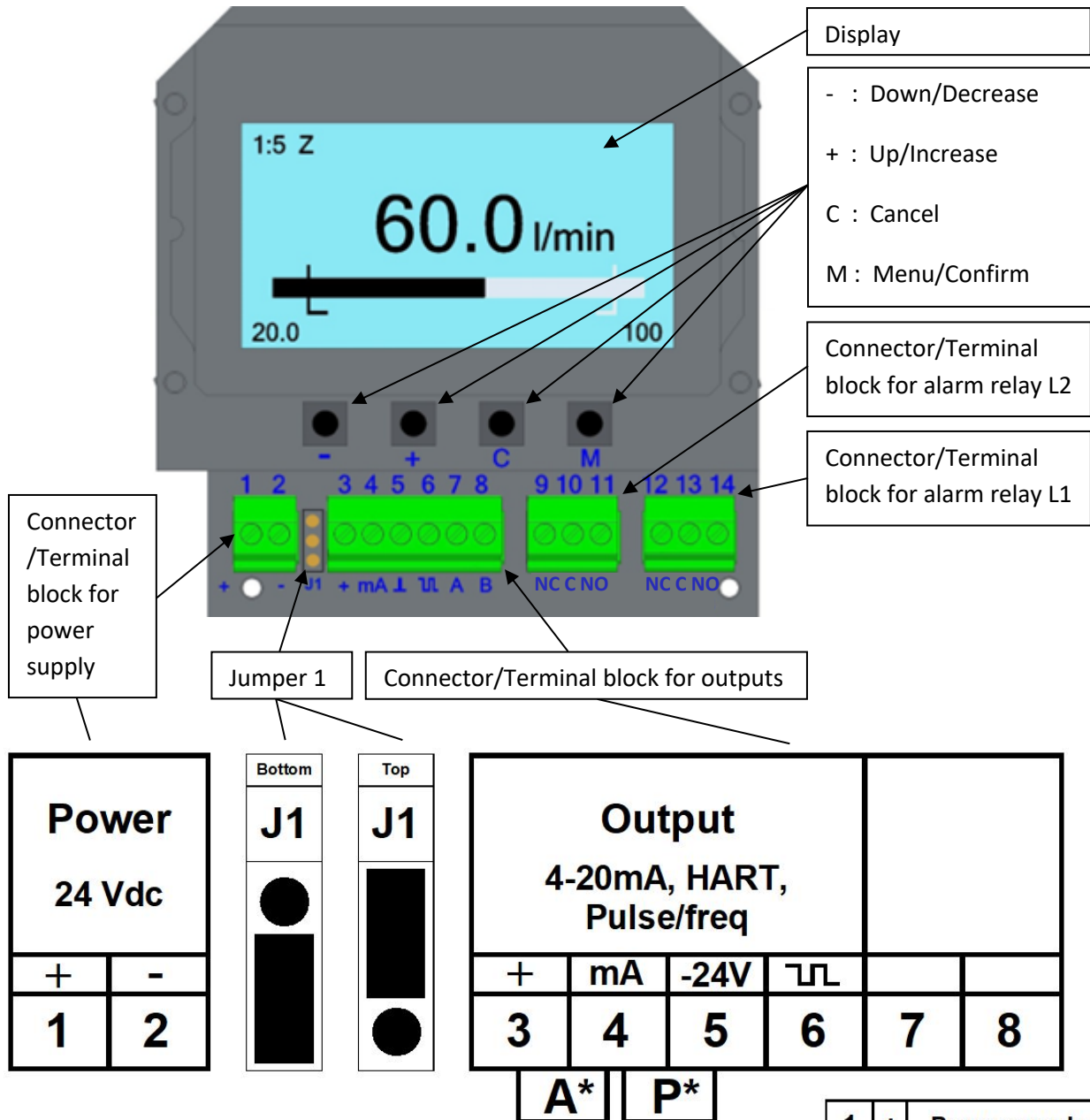

Fig. 10

When you fill up the system for the first time with liquid, please make sure that all entrapped air in the tubes/pipes between the Pipe Section and Control Unit is removed. The air can otherwise, as it is a compressible media, cause an inaccurate flow reading.

## 2.6 Electrical Installation



**Note!** The jumper fitting only affects the Pulse/freq. output.

**Note!** The pulse/freq. signal and the 4-20mA signal can only be connected at the same time by either connecting the 4-20mA signal in passive mode or connecting the pulse/freq. signal to the open drain circuit (J1 Top fitted).

**Note!** Output terminals are galvanic isolated from input terminals. Do not make common connection between power supply input terminals and output signals.

- \* A (Active mA drive) Max external impedance 250-500 ohms.
- \* P (Passive mA load) Max external voltage 25V. Use 24V for HART protocol.
- \*\* J1 (Top fitted) Open Drain, Max 25V 500mA, non-inductive load. mA can be connected in A/P.

1	+	Power supply
2	-	
3	+24V OUT	
4	mA*	
5	-24V	
6	PULSE/FREQ**	
7		
8		

\*\* J1 (Bottom fitted) 24V Signal out, 1000 ohms. mA can be connected just in P.

*Fig. 12*

Connect the unit according to the diagram above. Note that it is possible to release the upper part of the connectors to make it easier to connect the cable. Use cable type shielded twisted pair, min 0,2 mm<sup>2</sup>.

All terminal block connections are to be made through the included cable gland (PG9) and please note that you have two alternate mounting options of the cable gland depending on what side you want to enter with the cables. We recommend the entry of the cables to be placed in a downward or sideways direction, to avoid moisture/water to collect in the enclosure.



*Image 6*

## 2.7 HART Protocol Specification

<b>HART Revision</b>	5
<b>Supported Commands</b>	0, 1, 2, 3, 6, 7, 8, 11, 12, 13, 14, 15, 16, 17, 18, 19
<b>Multidrop</b>	Supported, use the “HART Multidrop” setting in the settings menu to lock the loop current to 4 mA
<b>Default Device Tag</b>	“ELETTA D”
<b>Burst mode</b>	Not supported
<b>Default Polling Address</b>	0

### 2.7.1 HART protocol point-to-point mode

The examples below illustrate how to connect HART modem with/without internal resistance or power supply.

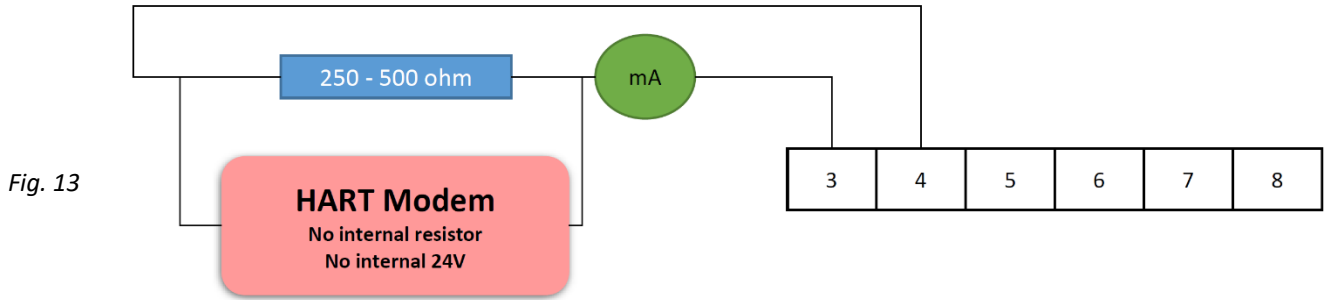

Figure 13 Example shows how to connect HART modem without resistance or power supply.

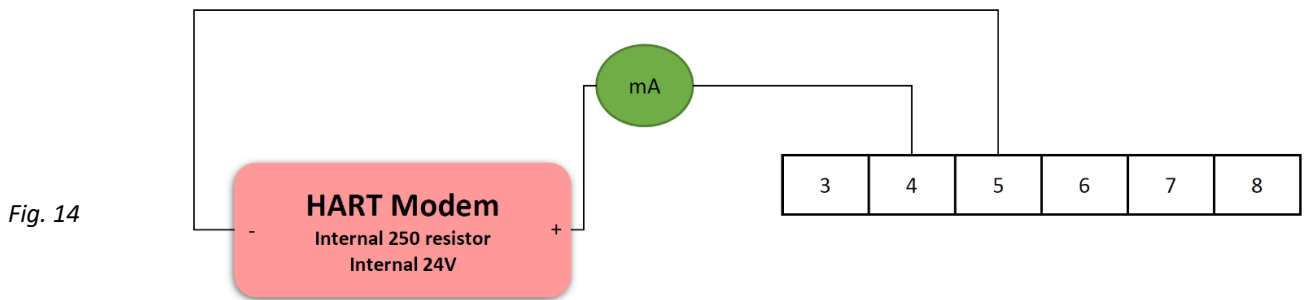

Figure 14 Example shows how to connect HART modem with internal resistance or power supply.

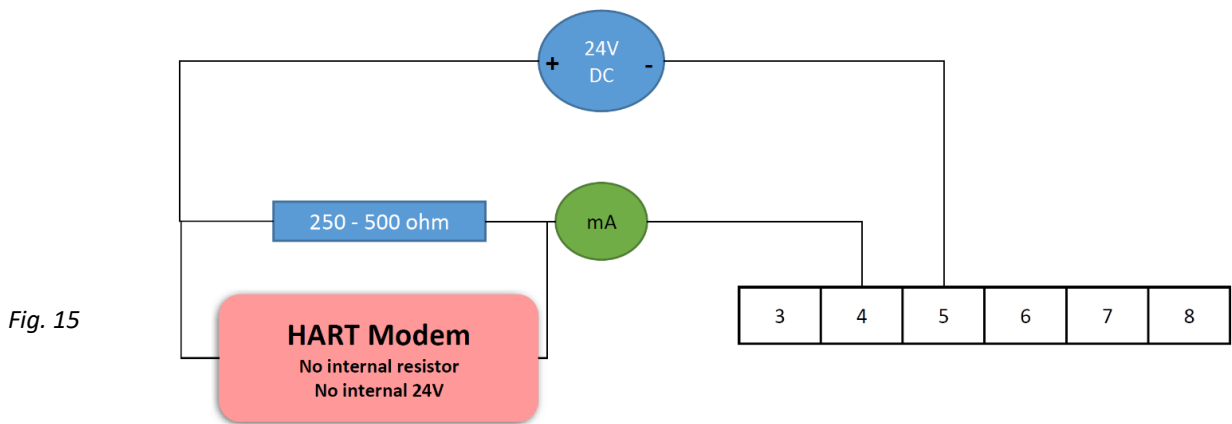

Figure 15 Example shows how to connect HART modem with an external resistance and power supply.

### 2.7.2 HART Identifying Device

The D-Series uses “0” as the default polling address, this can be used with command 0 to gather the detailed addressing information from the device.

## 2.8 Zero based / Non-Zero based Calibration

The analog 4–20 mA output signal is factory-calibrated in our flow rig to provide a **zero-based signal** by default (see below). A **non-zero-based signal** can also be specified when ordering. The key differences between these two calibration types are explained in the following sections.

### 2.8.1 Zero-Based Signal

A **zero-based signal** represents the *actual flow rate as a percentage of the maximum flow*. The maximum flow is determined by the Orifice Plate.

- **4 mA** corresponds to **0%** flow (no flow).
- **20 mA** corresponds to **100%** of the maximum flow.
- Below the minimum measurable flow, the output is fixed at **3.7 mA**.
- The minimum measurable flow depends on the **turndown ratio**:
  - 1:5 turndown → minimum flow = 20% of maximum flow
  - 1:2 turndown → minimum flow = 50% of maximum flow
- Above the maximum flow, the output is capped at **20.3 mA**.

**Model examples** (all percentages are of the maximum flow):

- **D2 Flow Monitor (1:2 turndown)**
  - 0–50%: fixed at **3.7 mA**
  - 50%: output jumps to **12 mA**
  - 50–100%: linear output from **12 to 20 mA**
  - above 100%: output capped at **20.3 mA**
- **D5 Flow Monitor (1:5 turndown)**
  - 0–20% of range: fixed at **3.7 mA**
  - 20% flow: output jumps to **7.2 mA**
  - 20–100%: linear output from **7.2 to 20 mA**
  - above 100%: output capped at **20.3 mA**

### 2.8.2 Non-Zero-Based Signal

A **non-zero-based signal** represents the *measuring range only*, rather than the full flow range starting from zero. The maximum flow is determined by the Orifice Plate.

- **4 mA** corresponds to the **minimum measurable flow**.
- **20 mA** corresponds to the **maximum flow**.
- Below the minimum measurable flow, the output is fixed at **3.7 mA**.
- The minimum measurable flow again depends on the **turndown ratio**:
  - 1:5 turndown → minimum flow = 20% of maximum
  - 1:2 turndown → minimum flow = 50% of maximum
- Above the maximum flow, the output is capped at **20.3 mA**.

Model examples (all percentages are of the maximum flow):

- **D2 Flow Monitor (1:2 turndown)**
  - 0–50% of range: fixed at **3.7 mA**
  - 50%: output jumps to **4 mA**
  - 50–100%: linear output from **4 to 20 mA**
  - 100%: output capped at **20.3 mA**
  
- **D5 Flow Monitor (1:5 turndown)**
  - 0–20% of range: fixed at **3.7 mA**
  - 20% flow: output jumps to **4 mA**
  - 20–100%: linear output from **4 to 20 mA**
  - 100%: output capped at **20.3 mA**

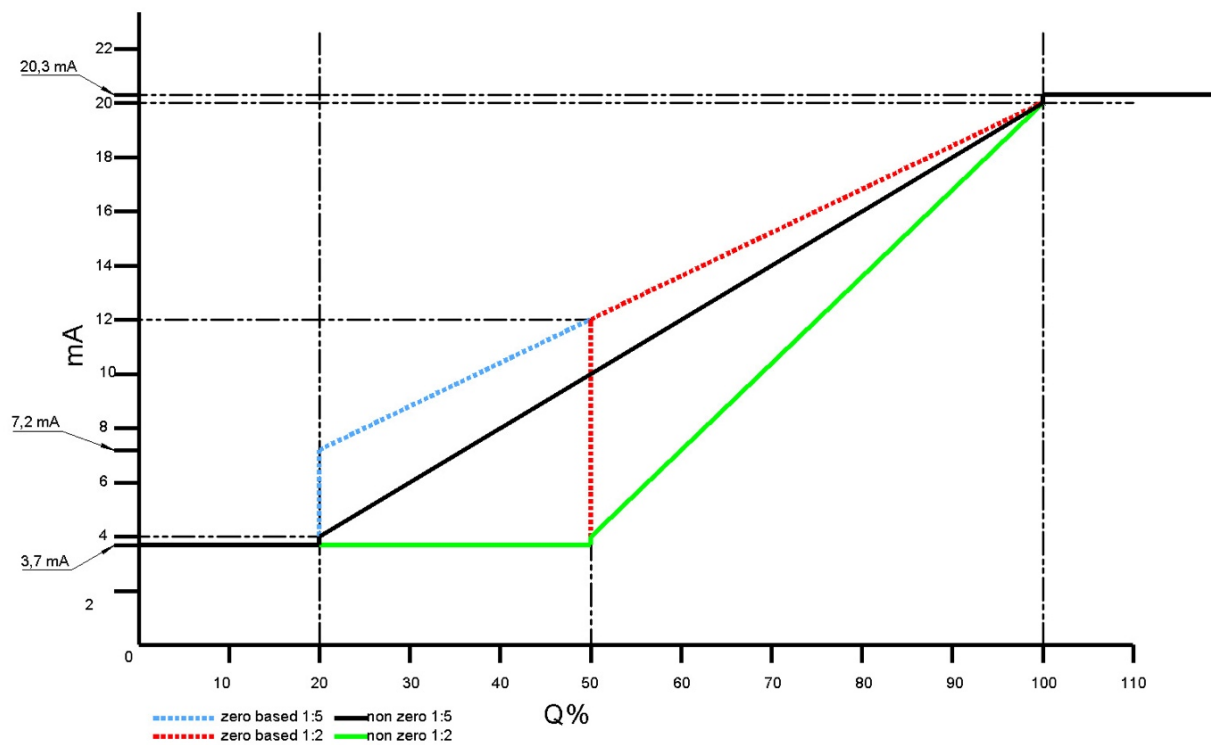

## 3 Operation

### 3.1 Display Settings

To change any information on the display, press the button “M” and hold for 2 sec. to reach the “Main menu”.

**Note!**

- i. No changes you make in the “Main menu” except Alarm and Simulation will have an effect on the flow meter function; it’s only a change of the displayed information.
- ii. Press the button “C” and hold for 3 seconds to save the changes. Otherwise, all changes are made will be canceled after power-cycling the unit.

#### 3.1.1 Overview

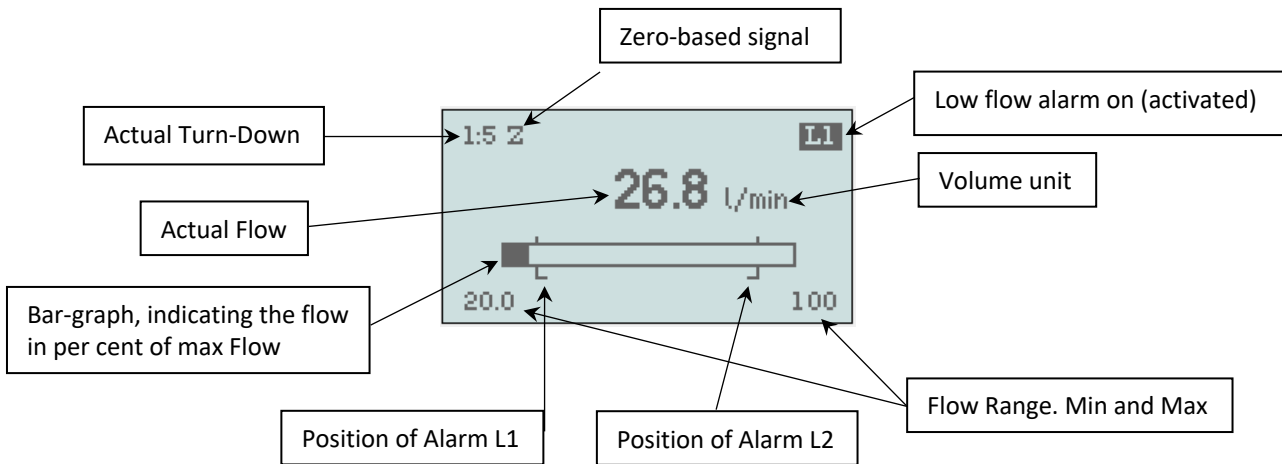

When you connect the power supply, the display lightens up, “Low flow” and “L1” will flash (if you don’t have any flow in process pipe).

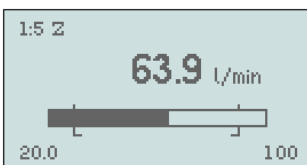

The flow value shows constantly as long as the flow is within the flow range. Within 2% below Q min and above Q max, the value will flash before it goes over to show “Low flow” or “High flow”



### 3.1.2 Language

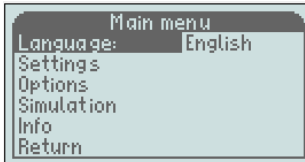

Scroll in the menu up and down with the buttons + or -.

When the text is highlighted (black), it means that you can change the parameters.

To change "Language"; press once more on the "M" button, to move to the right and change language with the buttons "+" or "-".

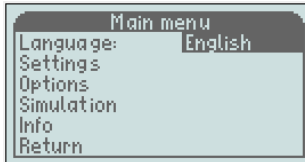

You can choose between:

English, French, German, Swedish, Spanish, or Chinese.

**Confirm the choice with "M" button.**

To leave this menu, scroll down to "Return" and press "M", or hold "C" button during 2 sec. "Return" takes you back one step in the menu, the "C" button takes you back directly to the operating mode.

### 3.1.3 Settings

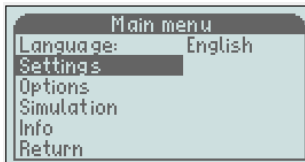

Scroll down to "Settings" with the "-" button, press the "M" once.

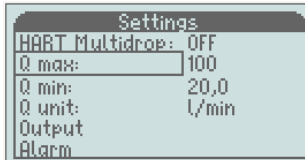

When there is only a frame around the word, you can't change anything as this is only an information field. In the example to the left you can see the actual flow range, Q max and Q min

#### HART Multidrop



HART Multidrop mode restricts the output current to 4mA, for use when multiple HART instruments are connected to a singular signal loop. To activate HART Multidrop mode; when "HART Multidrop" is highlighted press "M" to move to the right.

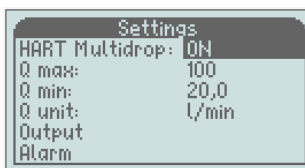

Use "+" or "-" to set "ON" or "OFF" and confirm with "M".

HART Multidrop mode will start or stop in the same time you confirm. Press "C" 2 sec. to go back to operating view.

#### Volume unit

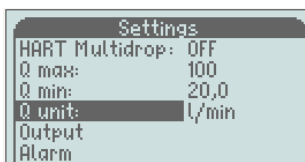

Scroll down to "Q unit" with the "-" button and press "M", to move to the right and now you can change the displayed units with "+/-" and choose between:

% (of Q max), l/s, l/min, l/h, m<sup>3</sup>/min, m<sup>3</sup>/h, USGpm, CFM, CFH.

**Confirm the choice with "M"**



To leave this menu, scroll down to "Return" and press "M", or hold "C" button during 2 sec. "Return" takes you back one step in the menu, the "C" button takes you back directly to the operating mode.

**Note!** For these changes you don't need to change the orifice, all figures will be recalculated to the displayed unit.

## Output

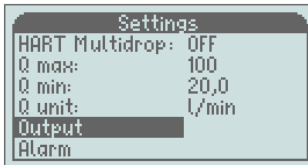

Scroll down to "Output" with the "-" button and press the "M" button.

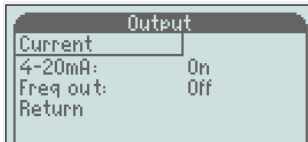

In this menu you can activate the frequency output. It gives a frequency of 200 to 1000 Hz or pulse.

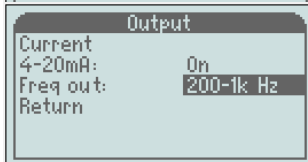

To activate the output, scroll down to "Freq out" and press the "M" button.

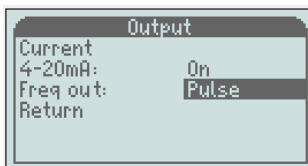

Use +/- to change to "200-1k Hz" or "pulse"  
**Confirm the choice with the "M" button**

To leave this menu, scroll down to "Return" and press "M", or hold "C" button during 2 sec. "Return" takes you back one step in the menu, the "C" button takes you back directly to the operating mode.

## Alarm



To change the alarm settings, scroll down with the "-" button to "Alarm" and press the "M" button



Scroll down with the "-" button to L1 trig or L2 trig and press the "M" button to set L1 or L2 to falling or rising. L1 is set to falling and L2 is set to rising by default from the factory.

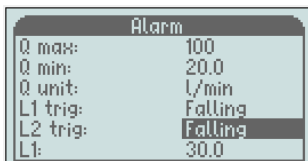

L1 and L2 can both be set to falling/falling or rising/rising.

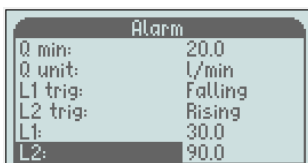

Scroll down with the "-" button to L1 or L2 and press the "M" button and the input box will light up.

To set the value of the alarm, you change the figure by figure with "+/-" and confirm with "M". Next figure will be highlighted and you repeat until you get your desired value.

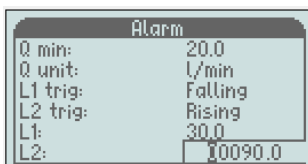

**Note!** It is not possible to set the alarm outside the flow range (Q min/Q max) Also the hysteresis effects on the alarm settings. L1 cannot be set higher than Q max - "Hyst1", and L2 can't be set lower than Q min + "Hyst2".

### Hysteresis



The hysteresis is necessary to avoid the alarm to ripple (go on and off) when the flow is close to the set point.

The hysteresis is changeable separate for each alarm between 2.5, 5 and 10% (of Q max).

To change the hysteresis, you scroll to that value you want to change and then press the "M" button so the value highlights and then use "+/-" to change and confirm with the "M" button.



To leave this menu, scroll down to "Return" and press "M", or hold "C" button during 2 sec. "Return" takes you back one step in the menu, the "C" button takes you back directly to the operating mode.

### Pulse

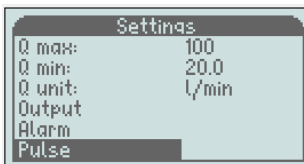

To change the pulse settings, scroll down with the "-" button to "Pulse" and press the "M" button

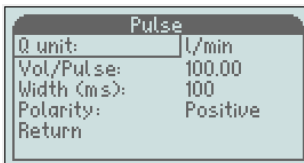

**Note!** The pulse needs to be activated in the "Output" menu for the pulse to work.

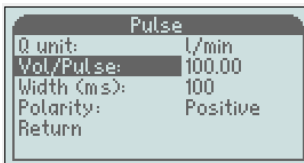

Scroll down with the "-" button to "Vol/Pulse" and press the "M" button and the input box will light up.

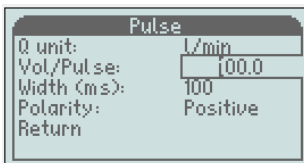

To set the pulse per unit volume, you change the figure by figure with "+/-" and confirm with "M". Next figure will be highlighted and you repeat until you get your desired value.

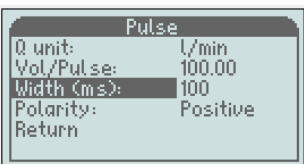

Scroll down with the "-" button to "Width (ms)" and press the "M" button and the input box will light up.

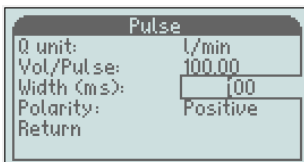

To set the pulse width, you change the figure by figure with "+/-" and confirm with "M". Next figure will be highlighted and you repeat until you get your desired value.

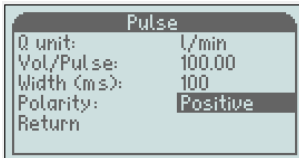

Scroll down with the “-” button to “Polarity” and press the “M” button to set the polarity to positive or negative.

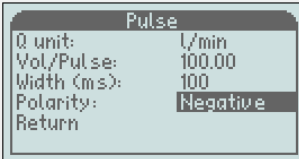

Confirm the choice with “M” button.

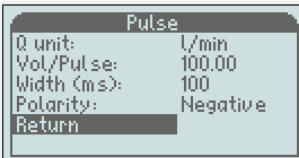

To leave this menu, scroll down to “Return” and press “M”, or hold “C” button during 2 sec. “Return” takes you back one step in the menu, the “C” button takes you back directly to the operating mode.

### 3.1.4 Options

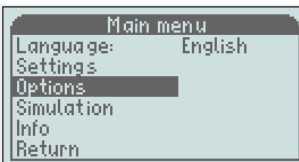

Scroll down to “Options” and press “M”

Here you can find the Totalizer, Display orientation and the Low pass filter.

#### Totalizer

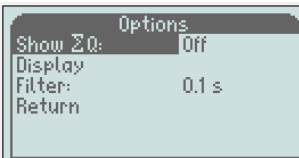

To activate the totalizer; when “Show  $\Sigma Q$ ” is highlighted press “M” to move to the right.

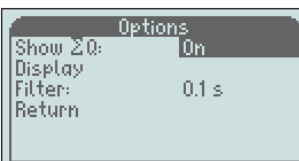

Use “+ or -” to set “On” and confirm with “M”.

The totalizer will start in the same time you confirm “On”. Press “C” 2 sec. to go back to operating view.

The value of the totalizer is the same as the displayed unit, so if you have l/min, l/s or l/h, the unit is liters, and if you have m<sup>3</sup>/min, m<sup>3</sup>/h the totalized value will be in m<sup>3</sup>.

**If you have the displayed unit in “%”, the totalizer will not work**

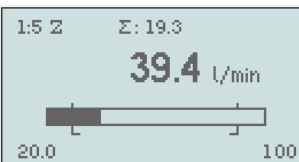

The totalizer works as long as the flow is within the flow range. If the flow should go outside the range or there is a power failure, the totalizer goes back to “Off” and also disappear from the display. If you want to go back to totalizing mode, you need to reactivate it.

It is also possible to restart the counter by press “-” in the “Operating mode”.

**Note!** The end value for the totalizer is 99999, when this value is reached the counter stops.

## Display

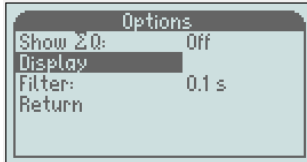

Depending on the mounting orientation of the Flow meter, the display can be rotated in 4 different angles, 0°, 90°, 180° and 270°.

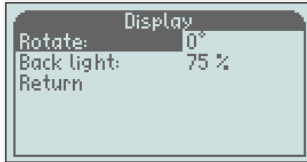

To change the orientation, scroll down to "Display" and press "M" and when "Rotate" is highlighted press "M" to move to the right. Use "+" or "-" to rotate to the angle you want, and confirm with "M".

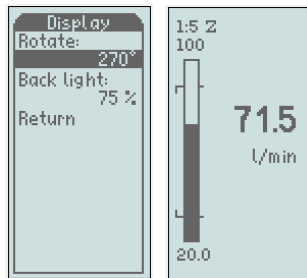

To leave this menu, scroll down to "Return" and press "M", or hold "C" button during 2 sec. "Return" takes you back one step in the menu, the "C" button takes you back directly to the operating mode.

## Back light

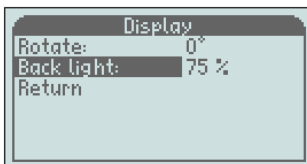

The backlight can be changed in 5 different levels, Off, 25, 50, 75 and 100%

To change it, press "M" when "Back light" is highlighted and use "+" or "-" to set the desired value. Confirm with "M".

To leave this menu, scroll down to "Return" and press "M", or hold "C" button during 2 sec. "Return" takes you back one step in the menu, the "C" button takes you back directly to the operating mode.

## Filter

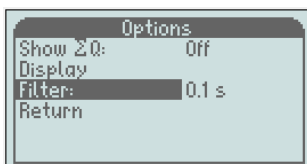

This filter will slow down the response time for the output signal and the displayed flow value.

It can be necessary to use this function if you are facing problems in your pipe system with pressure chocks or variations in the flow, giving the display and the output signal an instable value.

The filter can be set between 0 and 26 seconds, where level 0,1 sec is factory default setting.

**Note!** Don't set the filter higher than necessary as this will have an effect on detecting "true" changes in the flow.

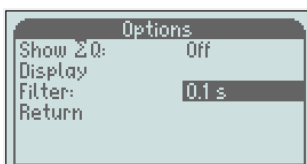

To change the filter value, scroll down in the "Options" menu until "Filter" will be highlighted. Then press "M" and the input box will light up.

To set the value you can change figure by figure with "+/-" if necessary and you confirm with "M". Next figure will be highlighted and you repeat until you get the desired value and then confirm with the "M" button

To leave this menu, scroll down to "Return" and press "M". "Return" takes you back one step in the menu.

### 3.1.5 Simulation

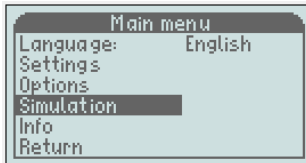

This function gives you the possibility to create and simulate a real mA-signal from the unit even if you don't have any flow. For example, you want to check other instruments or functions in your system. In this case you can simulate a desired flow or mA-signal from the unit. The simulation mode also allows for the testing of HART functionality, as HART protocol will transmit the simulated values.

**Note!** It's only possible to simulate the mA- and HART-signal, not the frequency output

#### Warning!!!

Before using this function, be sure that there is no flow in the system, as this simulation will disconnect the real signal and then disturb receiving instruments.

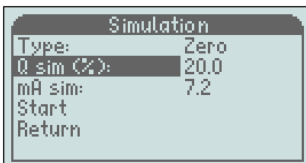

To activate the simulation, scroll down in the "Main menu" until "Simulation" will be highlighted and press the "M" button. Scroll down to "Q sim" or "mA sim" and press the "M" button, and the input box will light up.

To set your desired value you change figure by figure with "+/-" and confirm with the "M" button. The next figure will be highlighted and you repeat until you get the right value.

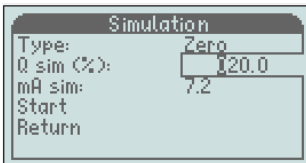

Confirm with the "M" button.

Scroll down to "Start" and press the "M" button to start the simulation

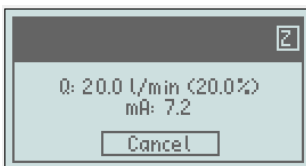

The display will flash between black/white during the simulation. To cancel, press the "C" button.

### 3.1.6 Info

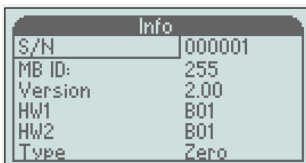

This menu will give you information about the version of software and hardware and also the type of output signal i.e. Zero-based or Non-Zero based.

### 3.1.7 Factory Default

#### Warning!! Warning!!

All changes in this menu will have an effect on the function of the flow meter.

This menu is only necessary when you change to a new orifice (another flow range), or want to change the output signal from Zero-based to Non-Zero-based or opposite or make a recalibration of meter. All other configurations will be made in the “Main menu”

From the operating mode you reach the “Factory default” menu by holding the buttons – and + simultaneously and keep them pressed for 2 sec until the menu lights up.

#### Note!

- i. Press the button “C” and hold for 3 seconds to save the changes. Otherwise, all changes are made will be canceled after power-cycling the unit.

#### Changing turn down

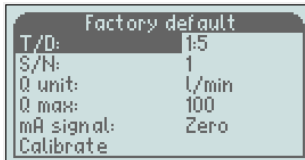

T/D: show you the actual flow turn down, in this case 1:5 (Q min is five times less than Q max).

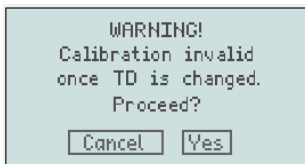

#### Warning!!!

If you change turn down you need to change both the orifice plate and springs within the diaphragm housing, you also need to do a recalibration.

**Do not** change turn down without consulting with the Eletta factory first.

#### Change flow range for a new orifice

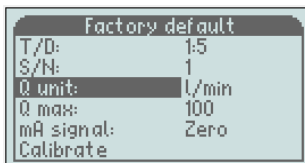

Scroll down to “Q unit” and press the “M” button to move to the right. Set the right unit for the new orifice by using “-/+”, and confirm with the “M” button.

**l/s, l/min, l/h, m<sup>3</sup>/min, m<sup>3</sup>/h, US GPM, CFM, or CFH**

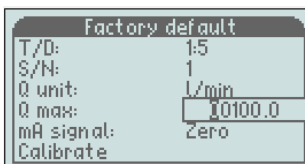

Scroll down to “Q max” and press the “M” button and the input box will light up. Set the right value according to the new orifice

To set the value you change figure by figure with “+/-” if necessary and confirm with the “M” button. Then next figure will be highlighted and you repeat until you get the right value.

#### Output signal

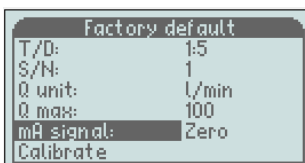

The output signal can be set in two different ways; “Zero” (zero-based) means that 4-20 mA represent 0-100% of Q max. This is most common and the factory default.

“Non-Zero” (non-zero-based) means that 4-20 mA represent the flow range (4 mA = min value of the flow range), see the graph on next page

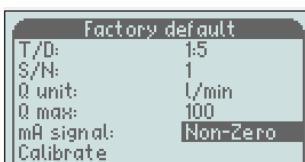

To change, scroll down to “mA signal” and press the “M” button to move to the right, and then change by using “-/+” and confirm with the “M” button

To leave this menu, scroll down to *“Return”* and press *“M”*. *“Return”* takes you back one step in the menu.

### 3.1.8 Calibrate

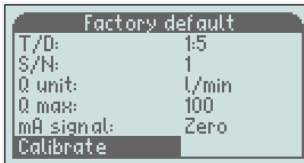

**Note! The Flow Meter is already calibrated from factory and it shall normally not be necessary to recalibrate.**

**If you still want to do this, you need a master meter so you can adjust to a correct flow.**

**A new flow calibration will overwrite the old factory calibration and it's not possible to recall it.**

#### Flow

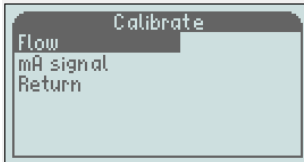

Scroll down to "calibrate" and press the "M" button and when "Flow" is highlighted press the "M" button once more.

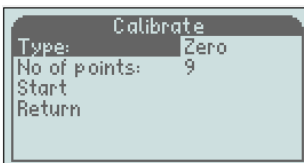

Chose "Type"; Zero or Non-zero, by pressing the "M" button and use "-/+ " to change and confirm with the "M" button.

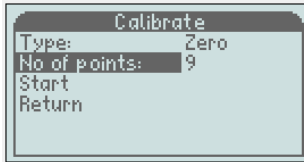

Scroll to "No of points" and choose how many calibration points you want to set. From factory, Turn down 1:5 is calibrated at 9 points and Turn down 1:2 at 6 points (D5 and D2 respectively).

Change the number of points by pressing the "M" button and the input box will light up.

Set the value with "+/-" and confirm with the "M" button.

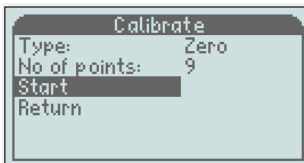

Scroll down to "Start" with "-" and press the "M" button

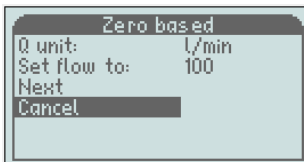

If you have come this far by mistake, you can interrupt the calibration without causing any changes here or you can go on with the calibration by adjusting a stable flow through your reference meter matching the value on the display "Set flow to".

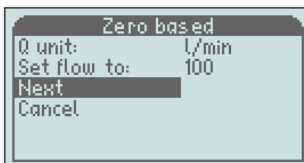

Move with "+" so "Next" will be highlighted and press the "M" button to confirm

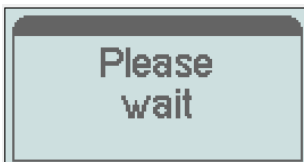

The adjusting of the calibration takes some seconds and during this time you need to keep the flow stable.

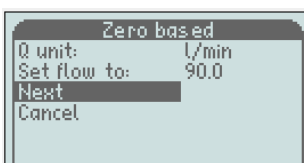

Next step in the calibration lights up and you can adjust to the flow the software ask for and press the "M" button to confirm.

**The calibration always start on Q max and finish on Q min and split automatically the calibration points proportional over the flow range.**

Repeat this procedure through the whole calibration.

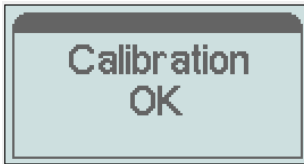

After the last calibration point you get a confirmation whether the calibration was “OK” or “Failed”.  
If the calibration was OK, the new calibration will be saved as default in the E<sup>2</sup>-memory and the display goes back to the factory default menu.

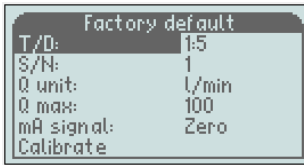

To leave the menu, scroll down to “Return” and press the “M” button, or hold the “C” button during 2 sec.

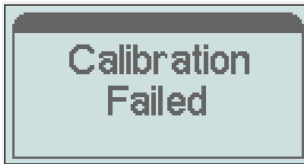

If the calibration Failed, the display goes back to the “Calibrate menu”, and you have to do a new calibration by starting from the beginning of the calibration procedure.

The old calibration is still saved in the E<sup>2</sup>-memory until a new calibration has passed OK.

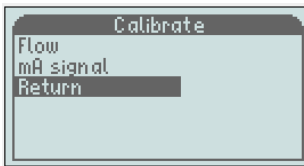

To leave this menu, scroll down to “Return” and press “M”, or hold “C” button during 2 sec. “Return” takes you back one step in the menu, the “C” button takes you back directly to the operating mode.

### 3.2 Change of Flow Direction

At the time of ordering your Flow Monitor you must always specify in which direction the Flow Monitor shall be mounted in i.e. from which side is the flow entering the Pipe Section and in which direction you would like to read the display. If you for some reason have ordered or received a Flow Monitor with the wrong flow direction, or if changes have been made in your piping system and you need to change the flow direction, it is possible to do this in the field.

GL- and FA-models are delivered with a flow direction selector that can be used for both directions. To change the direction, loosen the four (4) hexagon screws which hold the diaphragm housing to the Pipe Section. Remove the Control Unit and you will see the flow direction selector. Place the flow direction selector in the configuration for your system. There is a green marking indicating the flow direction.

The green dot marks the chosen flow direction, R for right and L for left.

Also remember to turn the red arrow mounted on the Pipe Section, to align with the new flow direction.

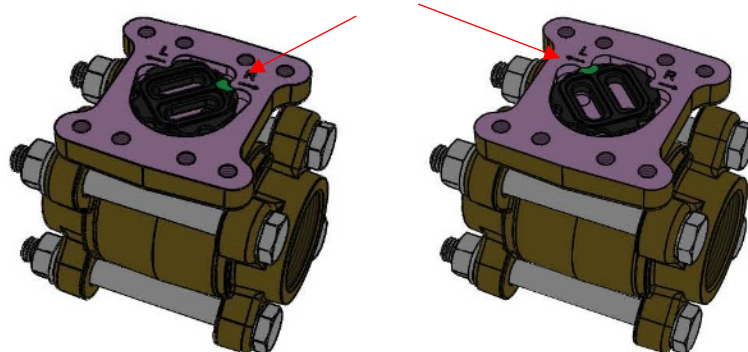

Image 7

For GSS and FSS, the flow direction is normally to the right. See image 8. If you want left flow, we mount the flow direction change block, between the indicator unit and pipe. See image 9.

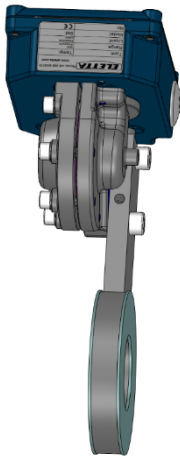

Image 8

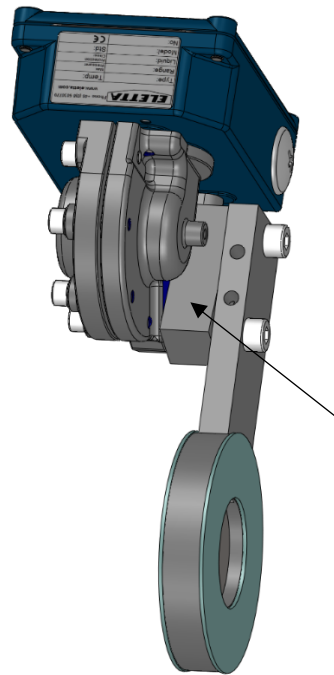

Image 9

Flow direction change block.

### 3.3 Change of Flow Range

The Eletta Flow Monitors features an orifice design that does not require recalibration after exchanging the orifice plate. This can be used in the field for easy change of flow ranges. The orifice plate inside the Pipe Section is the only part that has to be changed.

You can use any flow range and orifice plate that suits your application, as long as the flow falls within the limits of the range for the Flow Meter.

In each case of changing the orifice plate in-field, we kindly ask you to first contact your distributor or Eletta for advice about the correct orifice plate. The properties of each orifice plate are carefully calculated and designed to match the specific conditions of your installation.

#### **For threaded model –GL and GSS–**

Untighten the bolts that hold the Pipe Section between the flanges in the piping (do not remove the threaded parts from the piping). Remove only the number of bolts necessary to pull the Monitor from the piping, normally it takes only one bolt from the highest position, to get the Monitor out. Take out of the spacer that holds the orifice plate. Change the orifice plate to the new ordered orifice plate and remember that you can install it in any direction. Reinstall the spacer that holds the orifice in place inside the Pipe Section. Install the Monitor in the piping system again and tighten bolts firmly to avoid leakage.



Image 10

**For flanged model FA- and FSS-**

Follow the procedure above to loosen the pipe section from the counter flanges in the piping system, but note that the spacers are held in place with two screws, which has to be untightened before removal

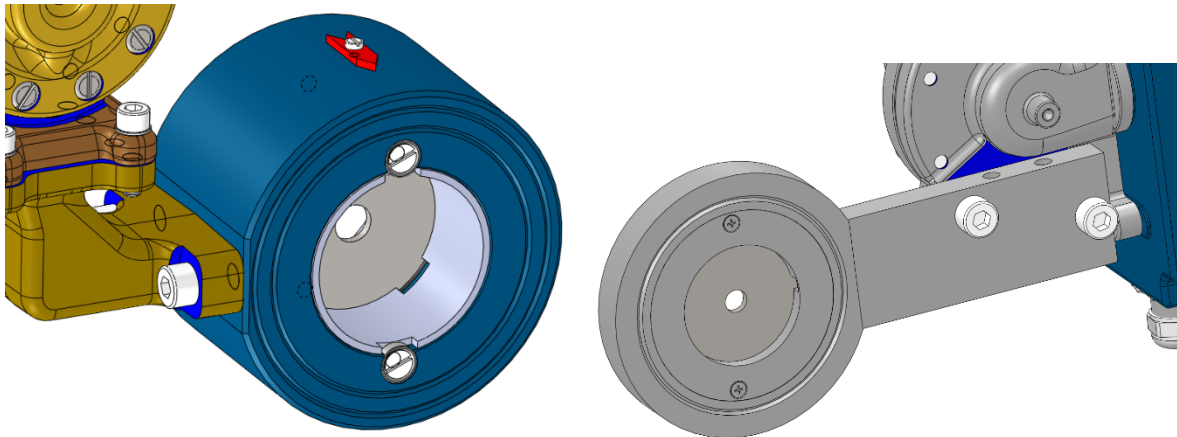

Image 11

**Change type plate**

When you change the orifice plate in order to get a new flow range, it is necessary to change the type plate to a plate with the new range marked. This type plate shall be specified together with the orifice plate when you order your new range.

**Change displayed flow range**

It is also important to change the displayed flow range in the digital display in order to get the correct displayed flow. This is done in factory default settings by changing Q-max to the maximum flow of your new orifice. See chapter 3.1.7 "Factory Default".

## 4 Differential Pressure Measurement

### 4.1 The Differential Pressure Principle

The function of the Eletta Flow Monitors is based on the proven and dependable differential pressure principle. The instruments use interchangeable sharp-edged orifice plates designed for different measurement ranges.

This is probably one of the oldest and most widely used principles for flow measurements. The principle benefits from simplicity and low cost. In addition, it exists a large amount of research data and experience, which is useful when predicting the behavior of a certain orifice plate.

Inserted into the Pipe Section of the Flow Monitor, the orifice plate constitutes an area restriction that causes a pressure drop after the orifice plate. This pressure drop varies with the flow rate. This means that in the flow direction, we will have one pressure before the orifice plate, and another after the plate. The first pressure will be slightly higher than the second.

The two pressures, before and after the orifice plate, are lead through two separate channels into the Control Unit. In most Eletta Flow Monitors, the differential pressure is sensed and measured by a mechanical mechanism inside the Control Units diaphragm housing. This mechanism transforms the movement into a Flow rate value given through the output signal.

The flow (**Q**) and the differential pressure (**ΔP**) are proportional to each other. The relation can be approximated by the formula  $Q = \sqrt{\Delta P}$ .

### 4.2 Pressure Drop

Since the Eletta Flow Meter is based on the Differential Pressure Principle, it is inevitable that a small permanent system pressure drop is caused. The reason is that the orifice plate reduces the flow area inside the pipe, and this will affect the pressure.

In our discussion, it is important to fully understand two types of pressure drops. The first is the actual pressure drop created between the both sides of the orifice plate. The second is the permanent pressure drop that will slightly effect the system.

The **actual pressure drop** is a temporary state that occur over the orifice plate. On the downstream side of the Flow Meter the pressure will try to get back to the same conditions as on the upstream side. Normally, the flow profile will be recovered on the downstream side after approximately 10-15 times the inner diameter of the pipe. However, due to friction losses caused by the orifice plate, the system pressure will not be able to reclaim all the energy (pressure), thus the system pressure will be somewhat less on the downstream side. This is what we call **permanent pressure drop**.

The permanent pressure drop can be calculated approximately by  $\Delta P_p = \Delta P_a * (1-\beta^2)$ , where the symbols represent:

$\Delta P_p$  = Permanent pressure drop

$\Delta P_a$  = Actual pressure drop (see the actual pressure drop formula on the next page)

$\beta$  = d/D Ratio. (d) = the diameter of the orifice bore. (D) = the inner diameter if the pipe.

Normally  $\beta$  is in the interval 0,2-0,7 resulting in a permanent pressure loss of 0.96  $\Delta P_a$ -0.51  $\Delta P_a$ .

**Example:**

For the Eletta Flow Monitor D2-GL15 with a flow range of 10-20 l/min, the following example can be used for how to calculate the  $\Delta P_p$  (permanent pressure drop) at 15 l/min for the said Monitor:

$d = 10,2 \text{ mm}$   
 $D = 16,0 \text{ mm}$

This gives a  $\beta$  of  $10,2/16,00 = 0,6375$ , which results in  $(1-\beta^2) = 0,594$

In order to use this  $\beta$  value in the above formula, we need to determine the  $\Delta P_a$ . We can either use the Actual Pressure Drop Graph to get an approximate value, or we can use the actual formula below. If we use the formula to calculate the  $\Delta P_p$  at 15 l/min we will get:

$$\Delta P_a = (15/20)^2 * 200 \text{ mbar} = 112,5 \text{ mbar}$$

In order to finally get the permanent pressure drop by using the above described formulas, we get  $\Delta P_p = \Delta P_a * (1-\beta^2)$ , which translated to values means  $\Delta P_p = 112,5 * 0,594 = 66,82 \text{ mbar}$ .

**Actual pressure drop formula**

For turn down ratio of 1:2

$$\Delta P_a = (Q/Q_{max})^2 * 2000 \text{ mmH}_2\text{O} \text{ (196 mbar)}$$

For turn down ratio of 1:5

$$\Delta P_a = (Q/Q_{max})^2 * 5500 \text{ mmH}_2\text{O} \text{ (539 mbar)}$$

$Q$  = The actual flow

$Q_{max}$  = Maximum flow of the Flow Monitor (according to the orifice plate)

Fig. 18

**Actual Pressure Drop Graph**

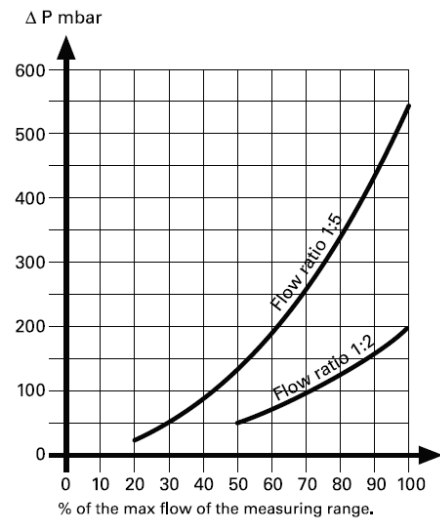

**Differential Pressure Range**

**Turn down 1:2 D2- (± 2% F.S. Reading) Dp-range: 500-2000 mmH<sub>2</sub>O**

Flow	50%			62,5%			75%			87,5%			100%		
	-2%		+2%	-2%		+2%	-2%		+2%	-2%		+2%	-2%		+2%
%	49,0	<b>50,0</b>	51,0	61,3	<b>62,5</b>	63,8	73,5	<b>75,0</b>	76,5	85,8	<b>87,5</b>	89,3	98,0	<b>100,0</b>	102,0
mA (Z)	11,8	<b>12,0</b>	12,2	13,8	<b>14,0</b>	14,2	15,8	<b>16,0</b>	16,2	17,7	<b>18,0</b>	18,3	19,7	<b>20,0</b>	20,3
mA (NZ)	3,7	<b>4,0</b>	4,3	7,6	<b>8,0</b>	8,4	11,5	<b>12,0</b>	12,5	15,4	<b>16,0</b>	16,6	19,4	<b>20,0</b>	20,6
mm H <sub>2</sub> O	480	<b>500</b>	520	750	<b>781</b>	813	1080	<b>1125</b>	1170	1471	<b>1531</b>	1593	1921	<b>2000</b>	2081
mbar	47	<b>49</b>	51	74	<b>77</b>	80	106	<b>110</b>	115	144	<b>150</b>	156	188	<b>196</b>	204

**Turn down 1:5 D5- (± 2% F.S. Reading) Dp-range: 220-5500 mmH<sub>2</sub>O**

Flow	20%			40%			60%			80%			100%		
	-2%		+2%	-2%		+2%	-2%		+2%	-2%		+2%	-2%		+2%
%	19,6	<b>20,0</b>	20,4	39,2	<b>40,0</b>	40,8	58,8	<b>60,0</b>	61,2	78,4	<b>80,0</b>	81,6	98,0	<b>100,0</b>	102,0
mA (Z)	7,1	<b>7,2</b>	7,3	10,3	<b>10,4</b>	10,5	13,4	<b>13,6</b>	13,8	16,5	<b>16,8</b>	17,1	19,7	<b>20,0</b>	20,3
mA (NZ)	3,9	<b>4,0</b>	4,1	7,8	<b>8,0</b>	8,2	11,8	<b>12,0</b>	12,2	15,7	<b>16,0</b>	16,3	19,6	<b>20,0</b>	20,4
mm H <sub>2</sub> O	211	<b>220</b>	229	845	<b>880</b>	916	1902	<b>1980</b>	2060	3381	<b>3520</b>	3662	5282	<b>5500</b>	5722
mbar	21	<b>22</b>	22	83	<b>86</b>	90	186	<b>194</b>	202	332	<b>345</b>	359	518	<b>539</b>	561

Fig. 19

## 5 Trouble Shooting

### 5.1 Inaccurate Flow Prediction

We would like to stress the fact that all the Eletta Flow Monitors are calibrated and adjusted individually with water in a specially purpose built calibrated flow rig in our factory. This means that we have calibrated the Monitors under reference conditions with enough straight runs before and after the Pipe Section.

If you find that the Flow Monitor does not show the same value as a reference meter on site, this could either be due to that the reference meter has been calibrated under other reference conditions, or that the Flow Monitor now is used under other conditions than the Eletta factory reference conditions.

#### **If your Flow Monitor shows the wrong value or nothing at all**

- Is there any output signal, at least 4 mA?
- Does the power supply use the correct voltage?
- Is there any flow in the system pipe?
- Is the Flow Monitor correctly mounted with respect to the flow direction? Check that the arrow on the Pipe Section corresponds to the media flow direction of the system.
- Is the flow sufficient to generate a differential pressure? The flow Monitor is designed for a minimum flow. Check the flow range.
- Do you have the correct orifice plate for the application? Check the product label
- If you use "tube fittings" when connecting the system pipes to the Pipe Section, make sure that they do not have inside diameters that are too small.
- Verify that you are using the correct inner diameter and enough straight runs up-stream and downstream of the pipe section.

#### **If you find process liquid/gas coming out of the Control Unit**

The most likely problem is that the diaphragm inside the diaphragm housing is broken and needs replacement. A new diaphragm is available to buy as a spare part. Contact the Eletta factory if there is any uncertainty on how to change the diaphragm. If there is liquid inside the blue housing, the problem is probably a broken lever that goes from the diaphragm housing into the blue housing. In this case you probably need to send the complete Control Unit back for repair since changing of the lever requires a recalibration of the unit which can be troublesome to do at site. It is also likely that the circuit boards inside the Control Unit has been damaged by the leaking liquid.

**You can always contact the Eletta customer support for help and recommendations if you have a problem with any of our products, we are happy to help you in the best way possible!**

### 5.2 Spares

We are proud to say that our Flow Monitors are well known for their long lifetime and robust construction but inevitable, it is sometimes needed to order spare parts. We refer to chapter 6 where you can find BOM drawings showing all components included in the Flow Monitor. If you have installed the Eletta D-series Flow Monitor in a very critical application, we recommend you to have a complete identically pre-calibrated Control Unit in stock, see chapter 2.4 on how to install a new Control Unit on your existing Pipe Section. The Pipe Section consist of no moving parts and all copper alloy/SS material and it is very rare with a breakdown of this part.

## 6 Spare Parts

### 6.1 BOM Drawing D-GL/FA

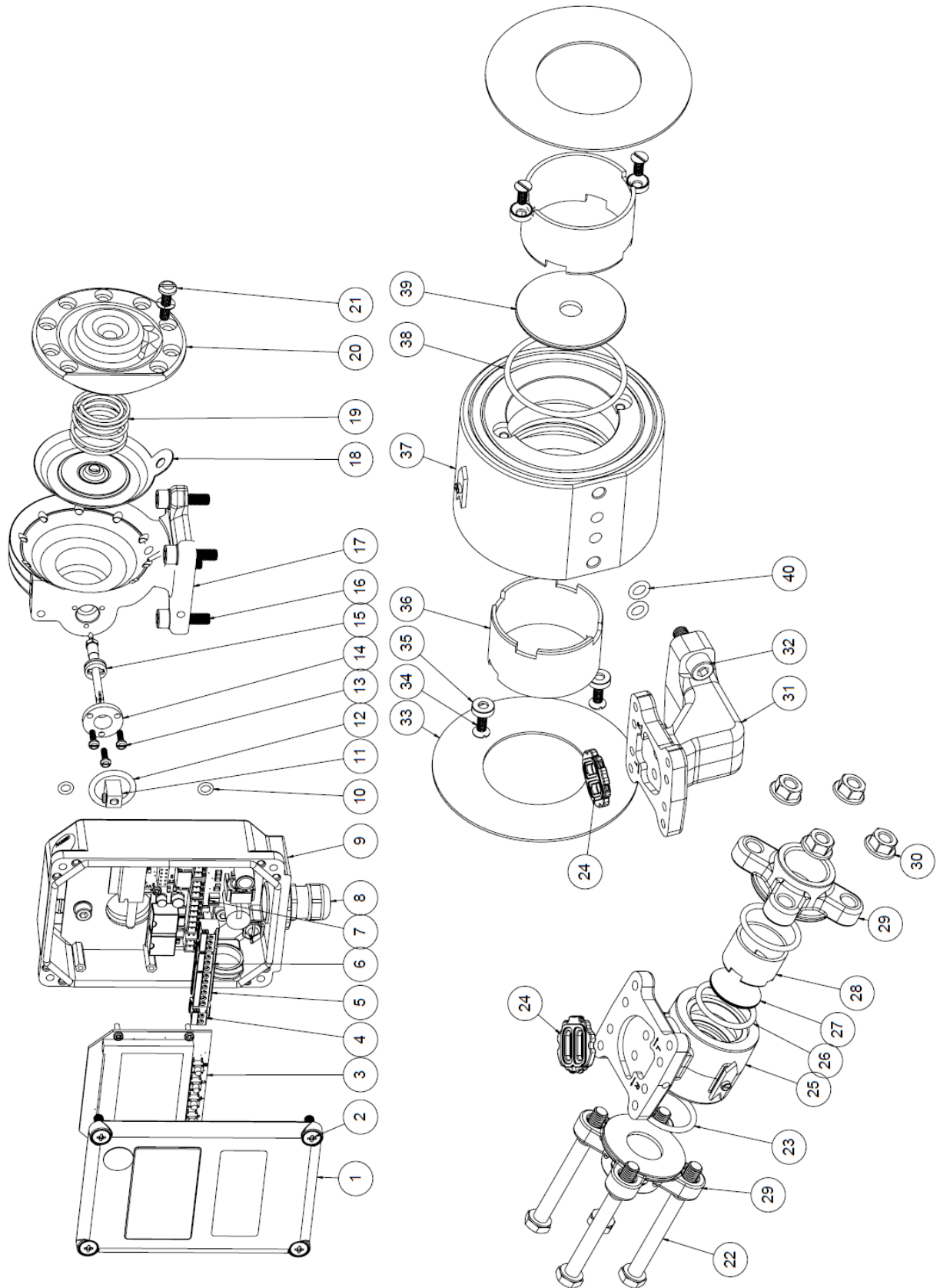

Pos.	Discription	Quantity
1	Cover	1
2	Screw	4
3	PCB Display	1
4	Terminal block (2)	1
5	Terminal block (6)	1
6	Terminal block (3)	2
7	PCB Power	1
8	Cable gland	1
9	Casing	1
10	O-ring	2
11	End pice	1
12	O-ring	1
13	Screw	3
14	Pressure flange	1
15	Lever	1
16	Screw	4
17	Diaphragm housing	1
18	Diaphragm	1
19	Diaphragm spring	1
20	Diaphragm cover	1
21	Screw with spring wacher	6
22	Screw	4
23	O-ring	2
24	Flow direction selector	1
25	Pipe body	1
26	O-ring	1
27	Orifice	1
28	Spacer	1
29	Threaded flange	2
30	Nut	4
31	Connecting body	1
32	Screw	2
33	Gasket	2
34	Screw	4
35	Wacher	4
36	Spacer	2
37	Pipe body	1
38	O-ring	1
39	Orifice	1
40	O-ring	2

6.2 BOM Drawing D-GSS/FSS

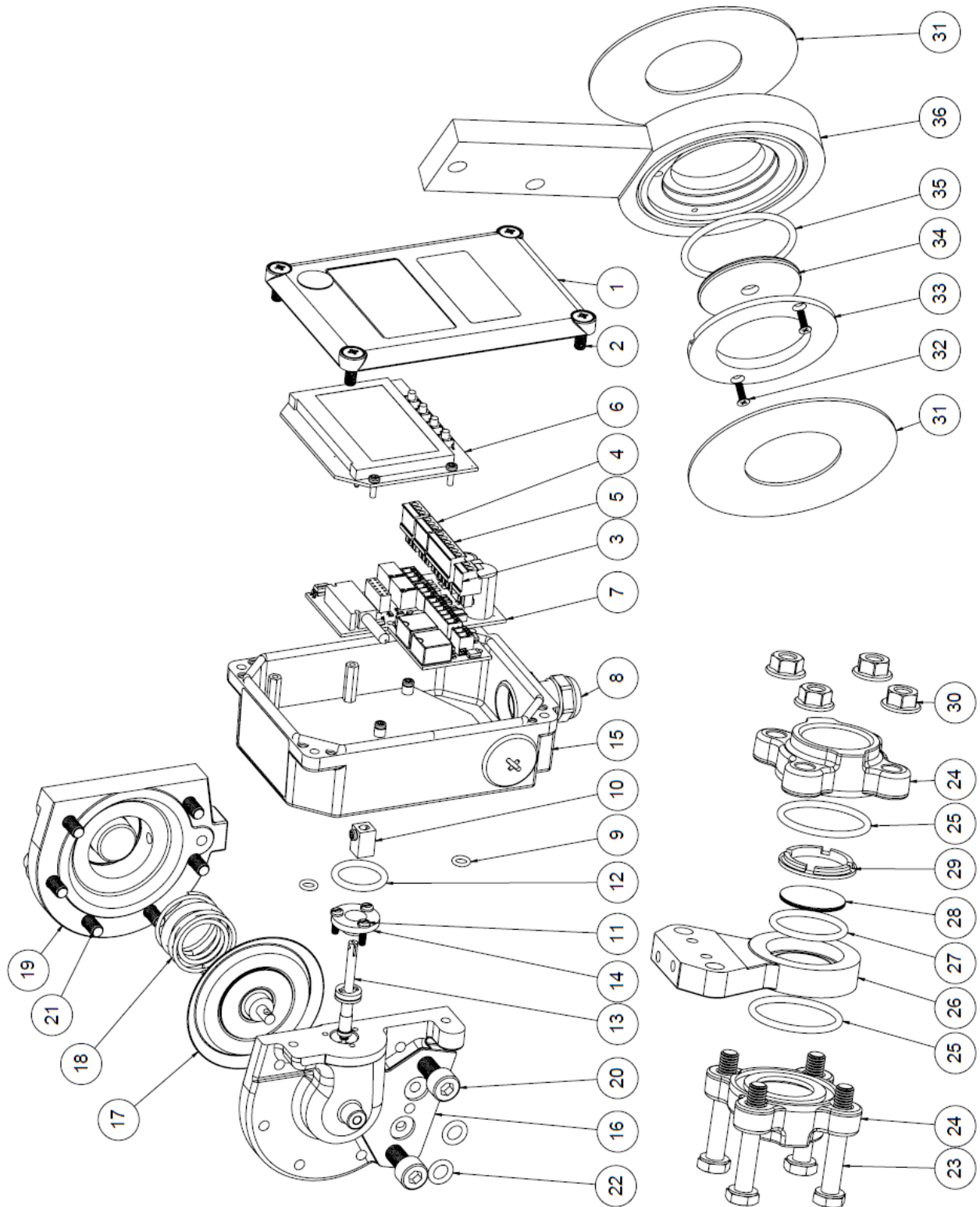

## D-GSS/FSS

Pos,	Descripton	Quantity
1	Cover	1
2	Screw	4
3	Terminal block (2)	1
4	Terminal block (3)	2
5	Terminal block (6)	1
6	PCB Display	1
7	PCB Power	1
8	Cable gland	1
9	O-ring	2
10	End pice D	1
11	Screw	3
12	O-ring	1
13	Lever	1
14	Pressure flange	1
15	Casing	1
16	Diaphragm housing	1
17	Diaphragm	1
18	Diaphragm spring	1
19	Diaphragm cover	1
20	Screw	2
21	Screw with washer	6
22	O-ring	2
23	Screw	4
24	Threaded flange	2
25	O-ring	2
26	Pipe body GSS	1
27	O-ring	1
28	Orifice	1
29	Spacer GSS	1
30	Nut	4
31	Gasket	2
32	Screw	2
33	Spacer	1
34	Orifice	1
35	O-ring Pipe body FSS	1
36	Pipe body FSS	1



## D-SS GSS/FSS

Pos.	Description	Quantity
1	Cover	1
2	Screw	4
3	PCB Display	1
4	PCB Power	1
5	Screw with wacher	2
6	Mounting plate	1
7	Spacer	1
8	O-ring	1
9	Casing	1
10	Cable gland	1
11	End pice D	1
12	O-ring	2
13	Screw wiht rubber steel wacher	1
14	O-ring	1
15	Lever	1
16	Diaphragm housing	1
17	Screw	2
18	Diaphragm	1
19	Diaphragm spring	1
20	Diaphragm cover	1
21	Screw with spring wacher	6
22	Screw	4
23	Threaded flange	2
24	O-ring	2
25	Pipe body GSS	1
26	O-ring	1
27	Orifice	1
28	Spacer	1
29	Nut	4
30	Gasket	2
31	Screw	2
32	Spacer	1
33	Orifice	1
34	O-ring	1
35	Pipe body FSS	1

## 7 Weight and dimensions

D - GL						
Type	D	A mm	B mm	C mm	E mm	Weight kg*
-GL15	1/2"	75	150	30	80	3,0
-GL20	3/4"	75	150	30	80	3,0
-GL25	1"	75	150	30	80	3,0
-GL40	1 1/2"	85	160	40	90	4,0

D - FA					
Type	d mm	D mm	A mm	Width mm	Weight kg*
-FA15	16 (1/2")	53	150	70	4,0
-FA20	22 (3/4")	63	154	70	4,5
-FA25	30 (1")	73	161	70	4,5
-FA32	39 (1 1/4")	84	167	70	5,0
-FA40	43 (1 1/2")	94	172	70	6,0
-FA50	55 (2")	109	180	70	6,0
-FA65	70 (2 1/2")	129	190	70	7,0
-FA80	82 (3")	144	197	70	8,0
-FA100	107 (4")	164	207	70	8,0
-FA125	132 (5")	194	222	70	10,0
-FA150	159 (6")	219	235	70	11,0
-FA200	207 (8")	274	263	70	15,0
-FA250	260 (10")	330	290	70	19,0
-FA300	310 (12")	385	320	70	21,0
-FA350	340 (14")	445	345	70	35,0
-FA400	390 (16")	498	375	70	40,5

D - GSS						
Type	D	A mm	B mm	C mm	Width mm	Weight kg*
-GSS15	1/2"	100	130	35	53	3,0
-GSS20	3/4"	100	130	35	53	3,0
-GSS25	1"	100	130	35	53	3,0

D - FSS					
Type	d mm	D mm	A mm	Width mm	Weight kg*
-FSS15	16 (1/2")	53	169	15	3,0
-FSS20	22 (3/4")	63	175	15	3,0
-FSS25	30 (1")	73	183	15	3,0
-FSS32	39 (1 1/4")	84	185	15	3,0
-FSS40	43 (1 1/2")	94	190	15	3,0
-FSS50	55 (2")	109	210	15	3,0
-FSS65	70 (2 1/2")	129	220	15	3,5
-FSS80	82 (3")	144	228	15	3,5
-FSS100	107 (4")	164	238	15	4,0
-FSS125	132 (5")	194	253	15	4,5
-FSS150	159 (6")	219	266	15	5,0
-FSS200	207 (8")	274	293	15	6,5
-FSS250	260 (10")	330	320	15	8,0
-FSS300	310 (12")	385	350	15	9,5
-FSS350	340 (14")	445	375	15	14,5
-FSS400	390 (16")	498	405	15	16,5

  

All stainless steel D-SS - GSS						
Type	D	A mm	B mm	C mm	Width mm	Weight kg*
-GSS15	1/2"	110	149	35	53	3,5
-GSS20	3/4"	110	149	35	53	3,5
-GSS25	1"	110	149	35	53	3,5

D-SS - FSS					
Type	d mm	D mm	A mm	Width mm	Weight kg*
-FSS15	16 (1/2")	53	179	15	3,5
-FSS20	22 (3/4")	63	185	15	3,5
-FSS25	30 (1")	73	193	15	3,5
-FSS32	39 (1 1/4")	84	195	15	3,5
-FSS40	43 (1 1/2")	94	200	15	3,5
-FSS50	55 (2")	109	220	15	3,5
-FSS65	70 (2 1/2")	129	230	15	4,0
-FSS80	82 (3")	144	238	15	4,0
-FSS100	107 (4")	164	248	15	4,5
-FSS125	132 (5")	194	263	15	5,0
-FSS150	159 (6")	219	276	15	5,5
-FSS200	207 (8")	274	303	15	7,0
-FSS250	260 (10")	330	330	15	8,5
-FSS300	310 (12")	385	360	15	10,0
-FSS350	340 (14")	445	385	15	15,0
-FSS400	390 (16")	498	415	15	17,0

\*Approximate weight

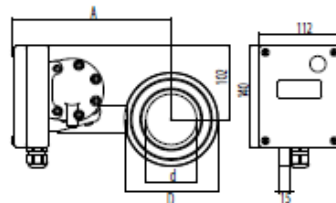
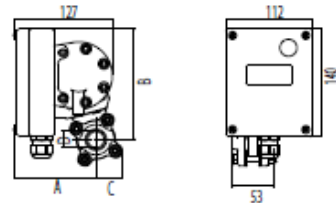
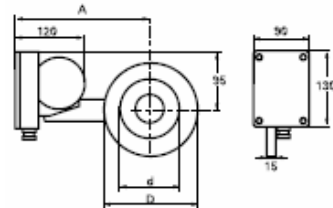
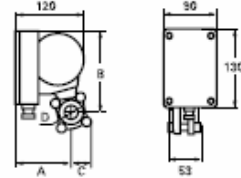
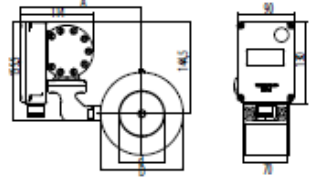
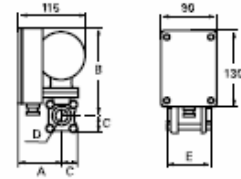

## 8 Measuring Ranges

The tables below are showing the standard measuring ranges for our Flow Monitors. The tables work as a guideline of what range that is achievable for different Pipe Sections and dimensions. It is possible to order different measuring ranges than indicated in the tables.

D2 (50-200 mbar)		
Dim. DN		lit/min
1/2" DN 15	GL, GSS FA, FSS	0,4 - 0,8
		0,6 - 1,2
		1 - 2
		1,6 - 3,2
		2 - 4
		2,4 - 4,8
		3,2 - 6,4
		4 - 8
		6 - 12
		8 - 16
3/4" DN 20	GL, GSS FA, FSS	4 - 8
		6 - 12
		8 - 16
		10 - 20
		12 - 24
		16 - 32
1" DN 25	GL, GSS FA, FSS	8 - 16
		10 - 20
		12 - 24
		16 - 32
		24 - 48
		36 - 72
FA, FSS	40 - 80	
	50 - 100	
1 1/4" DN 32	FA, FSS	20 - 40
		28 - 56
		40 - 80
		60 - 120
1 1/2" DN 40	GL FA, FSS	20 - 40
		28 - 56
		40 - 80
		60 - 120
FA, FSS	80 - 160	
	100 - 200	
2" DN 50	FA, FSS	40 - 80
		60 - 120
		80 - 160
		120 - 240
		160 - 320
2 1/2" DN 65	FA, FSS	60 - 120
		80 - 160
		120 - 240
		160 - 320
		240 - 480
3" DN 80	FA, FSS	120 - 240
		160 - 320
		240 - 480
		320 - 640
4" DN 100	FA, FSS	160 - 320
		280 - 560
		400 - 800
		600 - 1200
5" DN 125	FA, FSS	700 - 1400
		800 - 1600
		1000 - 2000
		1500 - 3000
6" DN 150	FA, FSS	600 - 1200
		800 - 1600
		1200 - 2400
		1400 - 2800
		1500 - 3000
8" DN 200	FA, FSS	800 - 1600
		1200 - 2400
		1600 - 3200
		2400 - 4800
		2500 - 5000
10" DN 250	FA, FSS	1600 - 3200
		2000 - 4000
		3200 - 6400
		4000 - 8000

D2-LP (12,5-50 mbar)		
Dim. DN		lit/min
1/2" DN 15	GL, GSS FA, FSS	0,2 - 0,4
		0,4 - 0,8
		0,6 - 1,2
		1 - 2
		1,6 - 3,2
		2 - 4
		2,4 - 4,8
		3,2 - 6,4
		4 - 8
		6 - 12
3/4" DN 20	GL, GSS FA, FSS	0,8 - 1,6
		2 - 4
		3,2 - 6,4
		4 - 8
		6 - 12
		8 - 16
1" DN 25	GL, GSS FA, FSS	1,4 - 2,8
		2 - 4
		4 - 8
		8 - 16
		10 - 20
		12 - 24
FA, FSS	16 - 32	
	20 - 40	
1 1/4" DN 32	FA, FSS	3 - 6
		6 - 12
		10 - 20
		16 - 32
1 1/2" DN 40	GL FA, FSS	4 - 8
		8 - 12
		8 - 16
		10 - 20
FA, FSS	20 - 40	
	50 - 100	
2" DN 50	FA, FSS	7 - 14
		16 - 32
		36 - 72
		40 - 80
		90 - 160
2 1/2" DN 65	FA, FSS	10 - 20
		16 - 32
		20 - 40
		40 - 80
		60 - 120
3" DN 80	FA, FSS	14 - 28
		36 - 72
		60 - 120
		120 - 240
		200 - 400
4" DN 100	FA, FSS	20 - 40
		40 - 80
		80 - 160
		160 - 320
		320 - 640
5" DN 125	FA, FSS	40 - 80
		80 - 160
		280 - 560
		500 - 1000
		750 - 1500
6" DN 150	FA, FSS	50 - 100
		120 - 240
		280 - 560
		600 - 1200
		750 - 1500
8" DN 200	FA, FSS	80 - 160
		160 - 320
		320 - 640
		600 - 1200
		1200 - 2400
10" DN 250	FA, FSS	120 - 240
		280 - 560
		600 - 1200
		2000 - 4000

D5 (22-550 mbar)		
Dim. DN		lit/min
1/2" DN 15	GL, GSS FA, FSS	0,4 - 2
		1 - 5
		2 - 10
		4 - 20
		6 - 30
		8 - 40
3/4" DN 20	GL, GSS FA, FSS	4 - 20
		6 - 30
		8 - 40
		15 - 75
1" DN 25	GL, GSS FA, FSS	6 - 30
		12 - 60
FA, FSS	16 - 80	
	24 - 120	
1 1/4" DN 32	FA, FSS	8 - 40
		20 - 100
		40 - 200
		50 - 250
1 1/2" DN 40	GL FA, FSS	8 - 40
		20 - 100
		40 - 200
2" DN 50	FA, FSS	60 - 300
		100 - 500
		160 - 800
		200 - 1000
2 1/2" DN 65	FA, FSS	20 - 100
		50 - 250
		100 - 500
3" DN 80	FA, FSS	40 - 200
		80 - 400
		160 - 800
		240 - 1200
4" DN 100	FA, FSS	80 - 400
		160 - 800
		250 - 1250
		400 - 2000
5" DN 125	FA, FSS	100 - 500
		200 - 1000
		400 - 2000
		600 - 3000
6" DN 150	FA, FSS	200 - 1000
		400 - 2000
		600 - 3000
		900 - 4500
8" DN 200	FA, FSS	400 - 2000
		600 - 3000
		1000 - 5000
		1500 - 7500
10" DN 250	FA, FSS	600 - 3000
		1000 - 5000
		1600 - 8000
		2400 - 12000

## 9 Recycling

Recycle your product and packaging at disposal



These products and packaging should not be mixed with general household waste. For proper recycling, please take these products to a designated collection point where they will be accepted free of charge.

Please contact your local authority or your household waste disposal service for further details of your nearest designated collection point.

Correct product disposal saves resources and prevents negative effects on human health and the environment.

Eletta Flow AB  
P.O. Box 5084  
SE-141 05 Kungens Kurva  
SWEDEN

E-mail [info@eletta.com](mailto:info@eletta.com)  
[www.eletta.com](http://www.eletta.com)  
Phone + 46 8 603 07 70 Switchboard  
+ 46 8 603 07 80 Orders and Inquires