

Manual Eletta Flow Monitor V2 and V25

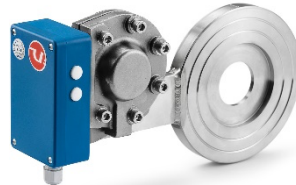

About this manual

- This manual relates to the V2, V25 Flow Monitor.
- Note that the latest version of this manual is always available as a PDF file on our web site www.eletta.com.
- On our site you will find other interesting information such as our product configurator where you can build your own Monitor, leaflets, certificates etc.

Proprietary Rights

This manual contains confidential technical data, including trade secrets and proprietary information, that are the property of Eletta Flow AB, Sweden.

Any changes or alterations to downloaded or printed Eletta original documentation such as manuals, drawings, leaflets, etc, are not permitted without a written permission from Eletta Flow AB, Sweden.

These data are only disclosed to you under permission of limited use within your company. Use for manufacturing or processing is not permitted.

Any other use of data and information is strictly prohibited without prior written permission from Eletta Flow AB, Sweden.

Distributors

Eletta has appointed a number of distributors all over the world. You will find more information about your closest distributor at our web site www.eletta.com, or by contacting our Customer Service Center.

Contact

Orders/inquiries: +468 603 07 80

Switchboard: +468 603 07 70

E-mail: info@eletta.com

Web: www.eletta.com

Address: Eletta Flow AB
P.O Box 5084
SE-141 05 Kungens Kurva
Sweden

Contents

1	General Information	4
	1.1 Description	4
	1.2 Specifications	6
2	Installation	9
	2.1 Unpacking	9
	2.2 Procedures before Installation	9
	2.3 Installation of the Pipe Section.....	10
	2.4 Separate mounting of the Pipe Section and Control Unit	11
	2.5 Installation and changing the Control Unit	13
	2.6 Pressure Drop	15
	2.7 Electrical Installation	17
3	Operation	18
	3.1 Principle of operation, DP-Flow Measurement.....	18
	3.2 Change of Flow Range	18
	3.3 Change of Flow Direction.....	20
	3.4 Adjustment of switch point	21
4	Trouble shooting	23
	4.1 Verification of Flow.....	23
	4.2 Electrical connections	25
	4.3 Spares.....	25
5	Tables	26
	5.1 Measuring Ranges	26
	5.2 Weight and Dimensions	27
6	Spare Parts	28
	6.1 Exploded Drawing V-GL/FA	28
	6.2 Exploded Drawing V-GSS/FSS	30
7	Distributors	32
8	Recycling	32

General Information

1.1 Description

The Eletta Flow Monitor is used to control and measure flow of liquids and gases in pipes from size 15 mm to 500 mm (larger pipes as an option). They have been manufactured for over 75 years and are well known for its reliability. They are used where operational safety demands, efficient supervision and rugged installation is needed, all over the world. Eletta Flow AB in Sweden is certified according to ISO9001 and ISO14001.

The Eletta Flow Monitor is based on the proven and dependable differential pressure principle, using interchangeable orifice plates for different measuring ranges. The Flow Monitors are working with two different differential pressure ranges, i.e. 50 – 200 mbar for the V2 and 22 – 550 mbar for the V25, depending on the desired and ordered flow range. The same goes for our models; V1 and V15, D2 and D5, S02/S2 and S05/S25. Due to the working principle of the instrument, it is of utmost importance that the installation instructions (chapter 2) are followed carefully in order to get the proper function of the instrument.

The Eletta Flow Monitor models V2 and V25 will give you a repeatable switch point of < 2% if installed in the right way. (See chapter 1.2 “Specifications”, for complete information.)

The Instrument consists of two parts mainly i.e. the Pipe Section and the Control Unit. The Pipe Section is the part that is to be mounted in the process pipe and the Control Unit is mounted directly (standard) or remote on/to the Pipe Section. The Control Unit contains the micro switches (SPDT) and the electrical connection terminal block. It also contains the mechanical adjusting screws where you change the setting of the flow alarm tripping point.

The Pipe Sections are available in different process connections with the following standards:

Threaded connections in BSP or NPT from 15 mm (1/2”) to 40 mm (1 1/2”) depending on the chosen material of construction.

Flanged (wafer) connection from DN15 /PN16 (ANSI 1/2”/150 lbs) to DN 500/PN16 (ANSI 20”/150lbs) depending on the chosen material of construction.

The mechanical movement from the lever that is transmitted via the diaphragm is created by the differential pressure over the orifice plate in the connecting pipe, in the same way as in our mechanical flow monitors V, D, R and S series. The lever mechanically affects the two microswitches which are adjustable over the whole ordered flow range, which can be set for low/high flow alarm within the chosen measuring range. These can be adjusted in field (see 3.4).

Product label

Each of our flow monitors wear a product label, see picture below with description.

		Phone +46 (0)8 6030770 www.eletta.com
Type:	Temp:	
Range:	Max Pressure:	
Liquid:	Protection Class:	
Model:	Std:	
No:	CE	

- Type: Model type of the flow monitor. For example, V25-GL15. Reference to section 1.2 Specifications for a thorough description of available types.
- Temp: The maximum operation temperature allowed for the control unit. Reference to section 1.2 Specifications for a thorough description of available types.
- Range: The flow range for which the flow monitor has been manufactured.
- Max Pressure: The maximum operation pressure allowed for the flow monitor.
- Liquid: The media which the flow monitor has been designated for.
Example: Water, oil etc.
- Protection class: IP -classification (International protection rating), of the control unit.
- Model: The article number of the flow monitor.
- Std: Pipe standard for which the flow monitor is designated. For example: DIN PN16, Dimensions according to DIN and pressure classification according to PN16.
- No: Serial number of the flow monitor. Each of our flow monitors have their own unique id number, which is used for traceability.
- Year of manufacturing.

1.2 Specifications

The *only* difference between the V2 and V25 is the turn down of the flow range i.e. the V2 has a **1:2** turn down (for example; 50 – 100 l/min) and the V25 has a turn down of **1:5** (for example; 40 – 200 l/min).

Repeatability: $\pm 2\%$ of actual pre-set tripping flow value.

It is recommended that you always chose the Flow Range of the Flow Monitor so that the normal flow is in the middle of the Monitor Flow Range. Make sure that the expected alarm set points is within the chosen flow range.

For example: If you have a flow of 110 l/min maximum and the normal Flow is at 90 l/min, choose the Eletta Flow Monitor V2 with a Flow Range of 60–120 l/min.

Pressure: Max: 16 bar, (232 PSI), higher test pressure as an option.
Min: A line pressure of appr. 0,7 – 1,0 bar is required for proper operation.

Temperature: Control Unit
-20°C to 90°C

Recommendation of choice of rubber material:

Rubber material	Min T °C	Max T °C
NBR	-20	80
EPDM	-40	100
FPM	-10	250

Higher **process** temperature possible with remote installation of Control Unit (*separate mounting, see section 2.4*).

Pipe Section:

The pipe sections GL all sizes and FA up to DN100 are equipped with spacers holding the orifice plate made of Polyamide plastic (PA) material and they can handle liquid/gas temperature up to 120°C (248°F). For higher process temperature, we recommend to use the stainless steel pipe sections, GSS / FSS which has no spacers.

Process connection:

DN15 – 40 (½” – 1 ½”) for GL-models
 DN15 – 25 (½” – 1”) for GSS –models
 DN15 – 400 (½” – 16”) for FA-models
 DN15 – 500 (½” – 20”) for FSS-models

Control Unit: IP43 (NEMA 3 R), standard
 PA12 Grilamid lkn-5h. Color RAL 5017.

Alarm indication:

On the V-series there is no visible micro switch indication to indicate if the switches are on or off.

Micro switch specification:

Type/Contact arrangement: SPDT
 Rating AC Voltage: 4 A @ 250 VAC
 Rating DC Voltage: 5 A resistive, 2,5 A inductive @ 28 Vdc
 Approvals: UL, CSA, 4A, 250 VAC

Material; Diaphragm housing and pipe section:

Type GL: Dezincified brass, CW602N/EN12420
Type GSS: Stainless steel 316L
Type FA: Housing: Dezincified brass, CW602N/EN12420
 Pipe section: Powder coated (2022009697096) steel
 1.0060 / E335 / SS1650
Type FSS: Housing: Stainless steel 316L
 Pipe section: Stainless steel 316 L

Material

diaphragm:

- Textile reinforced Hydrated Nitrile rubber (HNBR), standard on all models except stainless steel.
- Textile reinforced EPDM rubber, optional for all models.
- Textile reinforced Fluorinated rubber, FPM, standard in stainless steel models, optional for others.

**Material,
O-rings and
sealings:**

Follows the Diaphragm materials.

Spacer:

(FA and GL): GL pipes: Polyamide plastic (-10 to 120°C / 14 to 248°F)
FA pipes: DN15-100 Polyamide plastic (-10 to 120°C / 14 to 248°F)
DN125-400 stainless steel EN 1.4404 (ASTM 316L)

CE-**approvals:**

The Eletta Flow Monitors conforms with the EU directive for low voltage no: 2014/35/EU. We refer to the EU Declaration of conformity, document no 500A10E23, which will be sent to you upon request. It can also be found on www.eletta.com.

PED-**Directive:**

Complies with applicable parts in Pressure Equipment Directive 2014/68/EU. Conformity assessment has been performed according to module A. Internal production control combined with module A2. Internal manufacturing checks with monitoring of the final assessment, for category 2. Performed by Kiwa Inspecta. PED Declaration of conformity will be sent to you upon request and are also available on www.eletta.com.

Installation

2.1 Unpacking

We appreciate that you have decided to purchase our Products and we would like to ask you to begin the installation by checking your delivery against the Packing List. Please make sure to check the box for external damages before opening. If you find external damages, which have also led to damages to the Flow Monitor inside, you should contact the forwarder/shipper to claim replacement (or the cost of replacement). Check the Monitors' identification tag against your purchase order to make sure you have got the right articles with the right specifications.

All Monitors are individually packed in a carton. The box is made out of recycled environmental friendly material and we kindly ask you to deal with the waste material in a way that will have as little impact to the environment as possible.

2.2 Procedures before Installation

Note!!! Before any installation or maintenance work, disconnect all electrical power!

Please check that you are going to mount the Monitor at the lowest point in the piping system if you are measuring liquids and at the highest point if you are measuring gases. Also check if the planned flow direction in the system matches the one indicated on the Monitor. There is a red flow direction arrow on the outside of the pipe section (not the Stainless Steel-models which have a marking engraved on the side). If you find this to mismatch, we refer to section 3.3 "Change of Flow Direction", to adjust the internal flow director in order to match the desired flow direction.

Check that the pipe section has the right threads or the right flange standard to match your piping or counter flange.

If you are using the separate/remote execution i.e. Pipe Section and Control Unit installed in different locations, please check the plastic hoses for any damages or holes that can prevent proper function. The plastic hoses should not be used in temperatures over 90°C/16 bar (194 °F/232 PSI). If your application temperature exceeds this temperature/pressure we recommend using copper or stainless steel tubing, depending on the compatibility to the measured gas or liquid (see section 2.4)

2.3 Installation of the Pipe Section

Note!!! Before starting to install the Pipe Section, please make sure that the piping is not under pressure from flow of liquid/gas!

The pipe section can be installed in any desired direction, vertically or horizontally and the direction arrow on the pipe section denote the direction of the flow. It is very important that the pipe section is mounted with the correct direction, as the function of the Flow Monitor otherwise will be prevented. The piping shall be rigid and free from vibrations and hoses connected directly into the Monitors should be avoided as much as possible. If you have weak piping we advise you to use the M6 mounting hole (only on GL-series) on the backside of the pipe section, to fasten the pipe section to a wall or a rigid bracket. The straight runs before and after the Monitor should not be too short, in order to avoid disturbances, which can cause the Monitor to show incorrect values. We recommend giving at least 10-15 diameters upstream and 5 diameters downstream. (Please see Fig. 1)

Recommended installation of Pipe Section

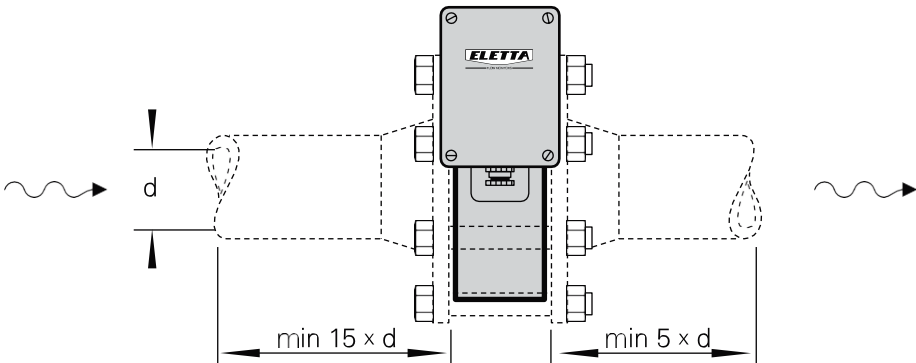

Figure 1, Recommended installation of Pipe Section

The reason for this procedure is to achieve a stable flow profile inside the pipe and by doing so, get a true reading. Please be aware of the fact that it is practically impossible to predict when the flow is stable after disturbances in the piping, so this must serve as a guideline only.

The straight runs must be free from valves, bends or in/decreasing diameters. Any of these disturbances must be placed **before** and preferably **after** you start counting the straight runs.

If you are installing the threaded versions, GL and GSS-versions, please make sure that you are not using so called **"tube fittings"**. We have often seen them to have a much smaller inside diameter than the pipe section, even though the size of the thread match. This can create a jet stream of the fluid or gas, which will cause the differential pressure to be too low and you, will not get a good or accurate reading.

The following inside diameters apply for the threaded Pipe Sections:

GL- and GSS 15 = **16 mm**

GL- and GSS 20 = **21 mm**

GL- and GSS 25 = **26 mm**

GL-40 = **40 mm**

Make sure that the Control unit, if mounted directly on the pipe section, is placed on top of the pipe section and not under to prevent particles in the fluid to collect in the diaphragm housing. Please consider using a filter in the pipeline if you suspect the fluid to contain particles.

The flanged models, FA and FSS, must be aligned with the counter flange and not placed in stress by tightening the bolts uneven. The flanged models come with a gasket and we recommend using this, as it is dimensioned to suit the installation. Please see to that the packing is properly aligned and not disturbing the flow. It is also of utmost importance that the connecting pipe and flange is of the same diameter (inside) and standard as the pipe section. A mismatch can cause an erratic or incorrect reading of the flow. If needed, please support the Flow Monitors with rigid brackets. There is no problem in attaching the brackets directly to the Flow Monitor (see above), but we recommend mounting them in the pipeline downstream and upstream to avoid unnecessary stress in the installation area.

2.4 Separate mounting of the Pipe Section and the Control Unit

Sometimes separate mounting of the Pipe Section and the Control Unit is requested due to vibrations, high temperature or lack of space. As the Eletta Flow Monitor is using the differential pressure caused by the orifice plate mounted in the pipeline and directs these two pressures via two individual ports up to the Control Unit, it is also possible to separate the Monitor into two parts.

The pressure is then lead through either plastic hoses or metallic tubing depending on the liquid, pressure and temperature. As a standard, we supply 2x1,75 meter (5.74 feet) of PA plastic, Ø 6 mm (0,23 inch) hoses capable of handling 90°C (194°F) and 16 bar (232 PSI), together with two specially made adapters to be mounted on the Pipe Section and Control Unit respectively. If your application requires metallic tubing (copper or stainless steel) it has to be provided locally. If you are measuring a chemical liquid or gas, check with the supplier which material you should use in your tubing. Please make sure to use only 6 mm tubing in order to suit the tube fittings included in the delivery.

There is no actual limitation in the length of the hoses or tubing, but we recommend placing the units as close as possible to each other, as this will help in troubleshooting and on-site calibration.

Note!!! The hoses/tubings must have the same length to avoid uneven pressure. If you mount valves (not included in delivery) in the pressure hoses/tubing, it will help you to easily shut them off and remove/exchange the Control Unit at full process pressure.

Please follow the above "Installation of the Pipe Section" after you have mounted the adapter on to the Pipe Section. As you will use hoses/tubing to lead the pressure up to the Control Unit, it is possible to mount the Pipe Section in any direction, vertically or horizontally and with the pressure ports pointing up, down or to the side (*pls. see to section 2.3*).

Separate mounting of Pipe Section and Control Unit GL/FA

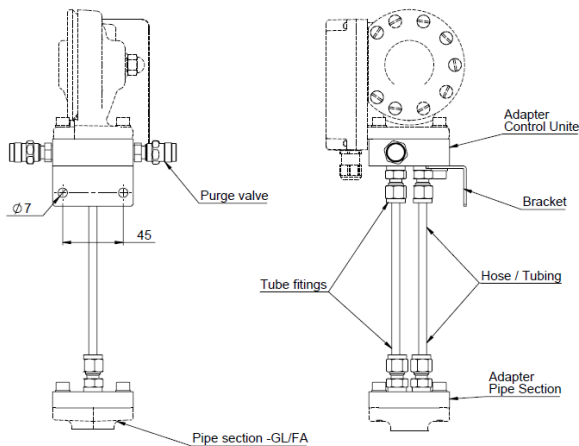

Figure 2, Separate mounting GL/FA

Separate mounting of Pipe Section – GSS/FSS

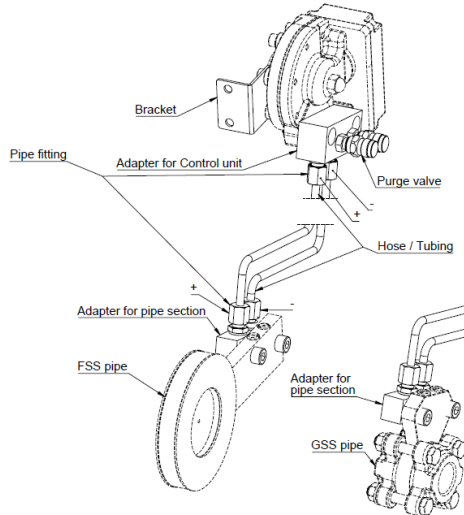

Figure 3, Separate mounting GSS/FSS

Find a suitable place for the Control Unit to be mounted. Use the supplied bracket to attach it to a wall, pipe or another steady and rigid support.

Install the hoses/tubing, commencing with the Pipe Section. Check that you have enough length to cover the distance between the Pipe Section and Control Unit. The Pipe Section adapter has a (+) and (–) marking engraved and the adapter on the Control Unit too. Please make sure to match (+) to (+) and (–) to (–) on the adapters. Press the hose/tube end into the coupling and tighten with care. Proceed to the Control Unit and repeat the above. When you fill up the system for the first time with liquid, please make sure that all entrapped air in the piping between the Pipe Section and Control Unit is removed. The air can otherwise, as it is a compressible media, cause faulty Flow readings.

2.5 Installation and changing of the Control Unit

As all Eletta Flow Monitors are designed in sections to achieve a modular and versatile Flow Monitor, there is a possibility to upgrade/rebuild them and adding other features to your already installed Monitor, by changing the Control Unit or Pipe Section.

If you, for example, would like to upgrade a V- or S-series with mechanical micro switches to a D-series including analog and/or frequency output, local front display and two independent adjustable relays or the other way around, this is easily done. You simply order a Control Unit with the flow range you need.

When you order, you will get the **Control Unit with the diaphragm housing included**. Make sure you order the right material in the diaphragm housing and the soft rubber parts (diaphragm, o-rings and diaphragm lever) and you will get the Control Unit already tested and calibrated and ready to fit onto the Pipe Section, without any on-site adjustments or calibration. All Eletta DP Flow Monitors are working with the same differential pressure within their specific range (*Pls. see section 1.1*).

As an option we have a manifold with shut-off valves, this enables you to dismantle the control unit from the pipe-section during full operation.

Start with making sure that there is no pressure in the system. Turn the electric power supply off and then disconnect the cables from the microswitch electric terminal.

On the -GL Pipe Section; loosen the four (4) hexagon screws that hold the diaphragm housing (do **not** remove the blue housing at any time) to the Pipe Section. Replace the flow direction selector (3.3.) if damaged, or if other material is required. Install the new Control Unit and tighten the four (4) hexagon screws firmly again.

On the -GSS Pipe Section; loosen the two (2) hexagon screws that hold the diaphragm housing and replace the O-rings to the right material, if necessary. Install the new Control Unit and tighten the two (2) screws firmly again.

On the -FA Pipe Section; loosen the four (4) hexagon screws that hold the diaphragm housing to the pipe section (do not remove the blue housing at any time) Replace the flow direction selector (3.3.) if damaged, or if other material is required. Install the new Control Unit and tighten the four (4) hexagon screws firmly again.

On the -FSS Pipe Section; Loosen the two screws that hold the diaphragm housing and replace the O-rings to the right material, if necessary. Install the new Control Unit and tighten the two screws firmly again.

Connect the electrical cables according to your new Control Unit's possibilities and for detailed information regarding wiring, please see section 2.7 "Electrical installation".

2.6 Pressure Drop

The Eletta Flow Monitor is a differential pressure measuring device and therefore it creates a certain pressure drop when in function. There are two different types of Pressure Drop's involved, **actual pressure drop** and **permanent pressure drop**. Below we will explain the difference between these two: When the orifice plate mounted in the Eletta Flow Monitor reduces the flow area inside the pipe system, a pressure drop over the orifice is created. This is what we call **actual pressure drop**.

The calculation of the flow is using this pressure drop to calculate the actual flow value (*see calculation below*). **The actual pressure drop** is a temporary pressure state and the Eletta Flow Monitors are working within this differential pressure created within the Flow range of the Monitor. When the flow has passed the Monitor, the pressure is then trying to get back to its original pressure and normally after 10 - 15 times the inner diameter of the pipe, the flow becomes linear and fully developed. This is a normalized flow but due to friction losses over our Flow Monitor, the pressure will not be able to reclaim all the energy (*pressure*). This is what we call **permanent pressure drop**.

The **permanent pressure drop** can be calculated approximately by $\Delta\rho_{(ppd)} = \Delta\rho_{(apd)}(1-\beta^2)$, where the symbols represent:

$\Delta\rho_{(ppd)}$ = permanent pressure drop

$\Delta\rho_{(apd)}$ = actual pressure drop for a certain flow

Please see below formula for calculating actual pressure drop.

$\Delta\rho$ = differential pressure flow measurement and

β = **d/D** ratio (ratio between bore and inner diameter of the pipe).

This means that for the normal β range (0.2 - 0.75) a typical permanent pressure loss ranges from 0.96 $\Delta\rho$ and 0.43 $\Delta\rho$ can be expected.

Example:

For the Eletta Flow Monitor V2-GL15 with a flow range of 10 - 20 l/min, the following calculation can be used as an example; bore = 10.20 mm inner diameter = 16 mm This gives $\beta = 10.20/16.00$ which results in $(1-\beta^2) = 0.594 * \Delta\rho$.

Actual pressure drop (differential pressure) at a flow of 15 l/min in the above example = 112,5 mbar (see calculation under fig. 4) Taken the above into consideration, at a flow of 15 l/min, the mentioned Flow Monitor will have an approximate **permanent pressure drop** of: $0,594 * 112,5 \text{ mbar} = 66,82 \text{ mbar}$

The Pressure loss curves in the graph (fig. 4) must serve as a guideline.

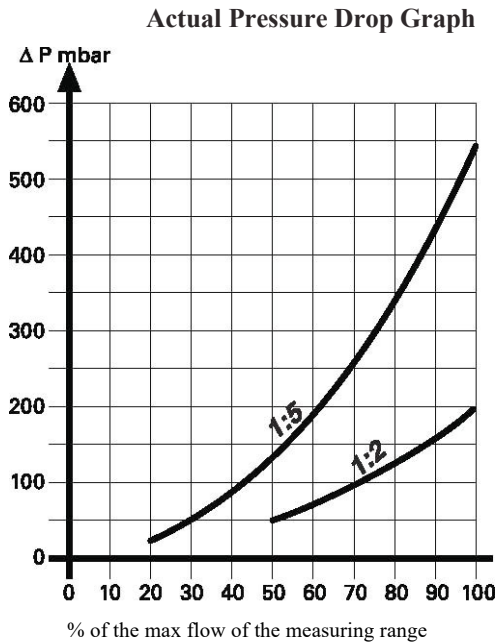

Figure 4, Actual Pressure Drop Graph

Please use the following formula to calculate Actual Pressure Drop in mbar:

The following formula can be used to calculate the actual pressure drop at a given flow if you have other flow than the example below:

$$\Delta\rho_{(apd)} = (Q/Q_{max})^2 * 2000 \text{ mm H}_2\text{O} \text{ (196 mbar) for turn down ratio of 1:2 and } \Delta\rho = (Q/Q_{max})^2 * 5500 \text{ mm H}_2\text{O} \text{ (539 mbar) for turn down ratio of 1:5}$$

Q = actual flow

Q_{\max} = maximum flow of the Flow Monitor (installed orifice plate)

$\Delta\rho$ = actual pressure drop in mbar

Example: Eletta Flow Monitor type V2-GL15, flow range 10 - 20 l/min.

Use the formula

$\Delta\rho_{(\text{apd})} = (Q/Q_{\max})^2 \times 200$ which gives; $\Delta\rho_{(\text{apd})} = (15/20)^2 = 112,5 \text{ mbar}$

2.7 Electrical Installation

Note!!! An authorized professional person should make all electrical installations and before any circuit is connected/disconnected, make sure that all power is off!

Before you connect any cables, please make sure that you have the right power supply which is within the specifications (see section 1.2 “Specifications”).

All terminal block connections are to be made through the included cable gland M12x1.5.

We recommend mounting the cable gland downwards to prevent condensation/liquid to enter.

The terminal block connections are described in fig. 5. Two grounding connections are to be found below the terminal block. The wiring diagram shows the switching function when the flow is zero or below the setpoint.

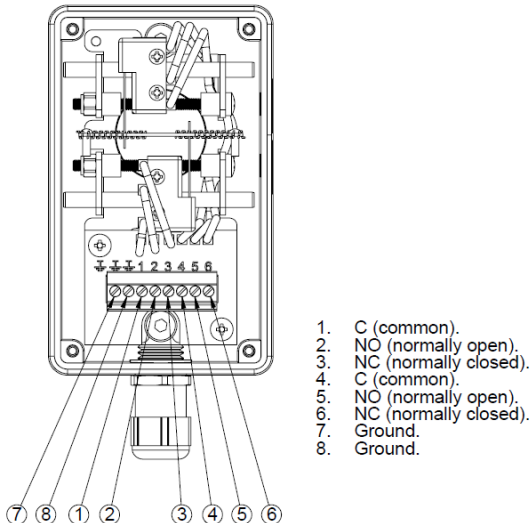

Figure 5, Wiring diagram

3.1 Principle of operation, DP-Flow Measurement

The Eletta Flow Monitor's function is based on the proven and dependable differential pressure principal, using interchangeable sharp-edge orifice plates for different measuring ranges. This is perhaps the oldest and most widely used principle for flow metering, mainly because of its simplicity, its relatively low cost and high volume of research data available for predicting the Flow Monitors behavior. In the Pipe Section, a fixed area flow restriction (the orifice plate) causes a pressure drop, which varies with the flow rate. This pressure drop has a high and a low pressure, which is lead through two channels from each side of the orifice plate to the Control Unit. By measure the pressure drop allows flow rate measurement by means of a mathematical formula.

A short form of the calculation can be described as $Q = \sqrt{\Delta p}$.

In most Eletta Flow Monitors, the differential pressure is sensed and measured mechanically via a rubber diaphragm and linked to an outside of the process liquid/gas. This mechanism transforms into a movement, which acts mechanically on the pre-adjusted microswitch.

The Indicating unit on all Eletta Flow Monitors are tested and approved according to the European CE-mark regulations. (Pls. check www.eletta.com for copy of the certificate.)

3.2 Change of Flow Range

The Eletta Flow Monitor features an orifice construction that does not require recalibration after replacement and can easily be rebuild in the field to change the flow range to another from the flow rate ordered.

If you need another flow range than ordered originally. The orifice plate inside the pipe section is the only part in the liquid/gas that has to be changed. You can order and change any flow range that suits your specific application, as long as the new flow rate falls within the total possible span for the actual Flow Monitor (*see Flow Rate table in section 6*).

In each case of rebuilding the flow Monitor in the field, we kindly ask you to consult Eletta or your local Distributor for advise of the right orifice plate before ordering.

First empty the piping system so it is un-pressurized and has no flow!

For threaded model -GL:

Untighten the bolts that hold the Pipe Section between the flanges in the piping (Do **not** remove the threaded parts from the piping). Remove only the number of bolts necessary to pull the Monitor from the piping, normally it takes only one bolt from the highest position, to get the Monitor out. Take out the spacer that holds the orifice plate. Change the orifice plate to the new ordered orifice plate and remember that you can install it in any direction. Reinstall the spacer that holds the orifice in place inside the Pipe Section. Install the Monitor in the piping system and tighten the bolts firmly to avoid leakage.

For threaded stainless steel model –GSS:

Untighten the bolts that hold the Pipe Section between the flanges in the piping (Do **not** remove the threaded parts from the piping). Remove only the number of bolts necessary to pull the Monitor from the piping, normally it takes only one bolt from the highest position, to get the Monitor out. Take out the spacer that holds the orifice plate. Change the orifice plate to the new ordered orifice plate and remember that you can install it in any direction. Reinstall the spacer that holds the orifice in place inside the Pipe Section. Install the Monitor in the piping system and tighten the bolts firmly to avoid leakage.

For flanged model -FA:

Follow the procedure above to loosen the pipe section from the counter flanges in the piping system, but note that the spacers ring is held in place with two screws, which have to be untightened before removal and reinstalled after.

For flanged stainless steel model -FSS:

Follow the procedure above to loosen the pipe section from the counter flanges in the piping system, but note that the spacers ring is held in place with two screws (FSS15-FSS150) or three screws (FSS200–FSS400), which have to be untightened before removal and reinstalled after.

Always check that no gaskets will interfere, by misaligning, with the flow when installing the pipe section.

Type plate

When you change the orifice plate in order to get a new flow range, we recommend you to change the identification plate to a plate with the new range marked. This identification plate shall be specified separately and comes together with the orifice plate.

The micro switch might be necessary to adjust and we refer to the section 3.4 for complete instruction on how to do this.

3.3 Change of Flow Direction

First empty the piping system so it is un-pressurized and has no flow!

At the time of ordering, you must specify in which direction the Flow Monitor shall be mounted i.e. from which side is the flow entering the Pipe Section. (Please refer to fig. 6 below for alternatives.) If, for some reason, the Flow Monitor is ordered with the wrong flow direction, it is possible to change this in the field.

GL- and FA-models are delivered with a flow direction selector that can be used for both directions.

To change the direction, loosen the four (4) hexagon screw, which hold the diaphragm housing to the Pipe Section. Remove the diaphragm housing and you will see the flow direction selector (it might have attached itself to the bottom side of the diaphragm housing). Replace the flow direction selector in the configuration for your system (see fig. 6). Please also remember to turn the red arrow mounted on the Pipe Section (-GL and -FA models), to align with the new flow direction.

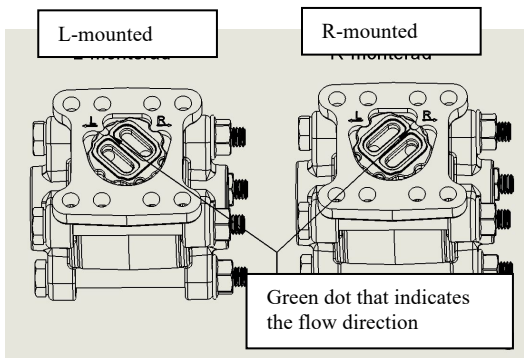

Figure 6, Flow direction selector

To change the flow direction for GSS and GSS pipes, you can order a block that changes the flow direction (see fig 7).

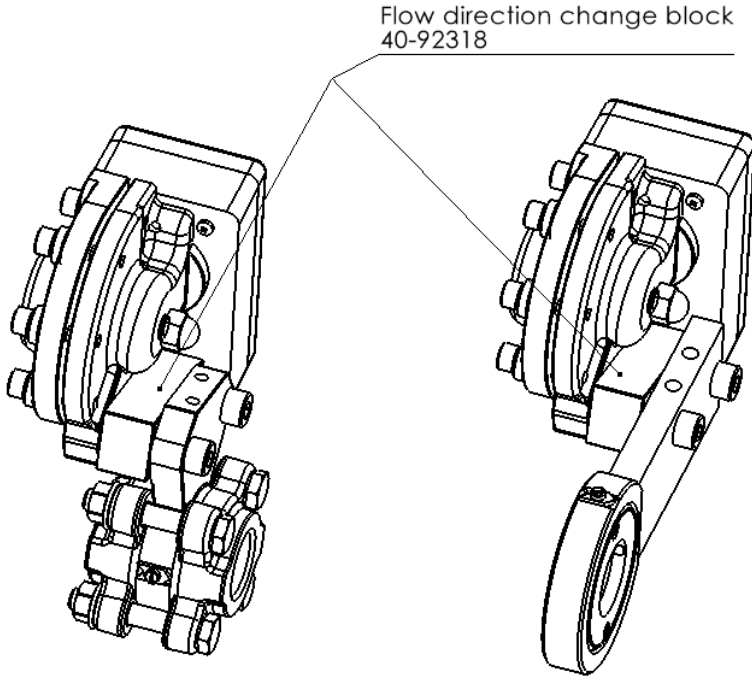

Figure 7, Flow direction selector

The pipes GSS and FSS are manufactured with the flow direction R, see fig 8. If you want the flow direction L, see fig 8, you must supplement with an extra block. This flow direction change block is placed between the pipe and the membrane housing, see fig 7.

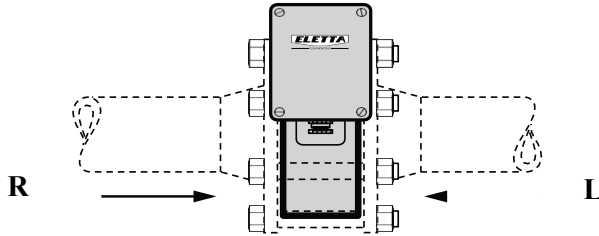

Figure 8, Flow direction alternatives

Flow direction alternative

3.4 Adjustment of switch point, V2 and V25

The Indicating unit on all the Elettta Flow Monitors are tested and calibrated according to the customers' orders before shipping. If the customer does not specify a desired switch point the alarm is set at min and max value of the ordered range. For example a 10 - 20 l/min flow range would have the switch set to trip at 10 l/min and 20 l/min.

Please note!! We have calibrated each and every Indicating unit in our flow rig and set the switches according to the Flow values we achieve in the rig under good conditions. We must stress that under actual field conditions, the flow profile can be different from the one in our flow rig depending on valves, hoses, bends or other obstructions and therefore the actual switching can be off from our preset values.

The V2/V25 has two adjustable microswitches, type SPDT with contact surface of silver. There is a possibility to adjust the switch/alarm point in the field.

To adjust the micro switches' position mechanically, just, remove the silicon plugs and the adjusting screws are visible.

Use a screwdriver to adjust the switch point by gently turn the screw in desired way, (se fig 8). Reinstall the cover and start up the process again.

See fig below for instructions.

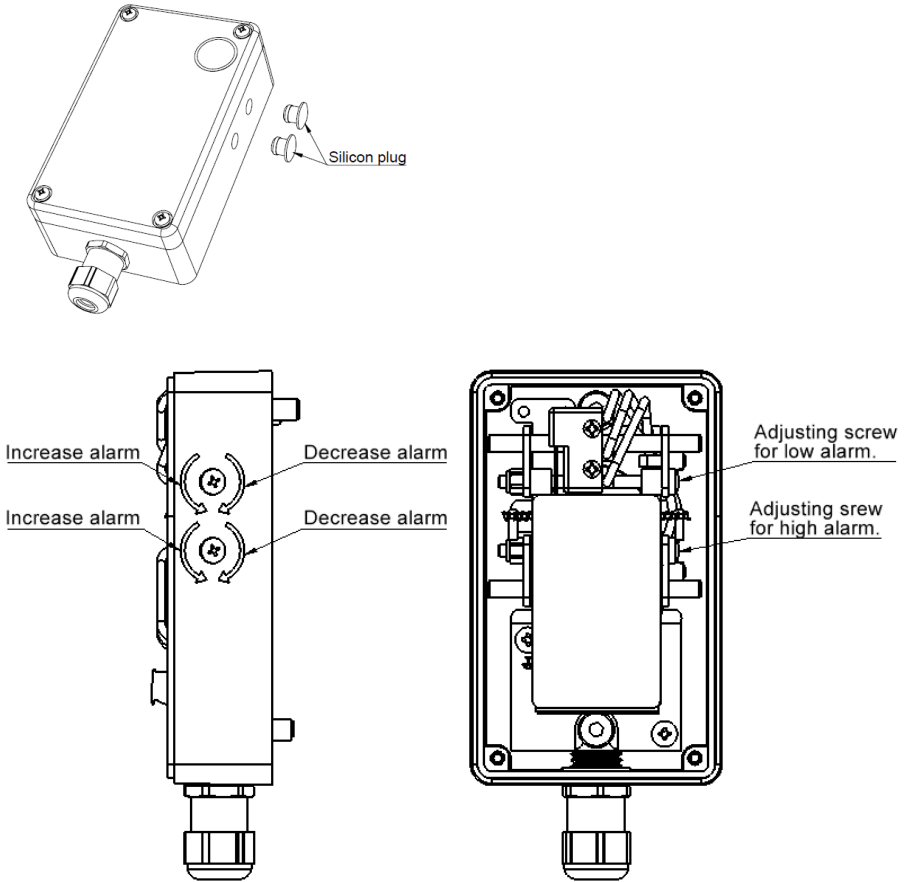

Adjusting of high/low flow alarm for V2/V25

Figure 8, Adjusting of alarms

Trouble shooting

4.1 Verification of flow

We would like to stress the fact that all the Indicating units on Eletta Flow Monitors are calibrated and adjusted individually on water in a specially purpose built calibrated flow rig in our workshop. This means that we have calibrated/adjusted the Monitors under reference conditions with enough straight runs before and after, always the same liquid, temperature, flows and pressure. If you find our Monitors to show another value compared to a reference meter on site, it can well be due to the fact that the reference meter has been calibrated under other reference conditions and that our Monitor have other conditions on site in the actual application, than we used under the calibration prior to shipping. We calibrate all our Monitors against flow and not pressure.

The meter is not giving an alarm:

- Is there any power supply connected?
- Is the Monitor mounted correctly with respect to the flow direction? Please check the arrow on the outside of the pipe section with the actual (true) flow direction for GL- and FA-models, check the flow direction selector inside the monitor. Lift the control unit and check the arrow on this part. Make sure that it is corresponding to the true flow.
- Is there any flow in the pipe? And is it enough to create the needed ΔP ?
- Do you have the right orifice plate for the application? Check the stamped values on the orifice plate. (Pipe section model number and flow)
- If you are using compression couplings into the Monitor inlet, check that the inside diameter is enough to avoid the “nozzle” effect described above in section 2.3 and also check the table for the minimum correct inner diameter in the same section.
- Are the straight runs before and after the Flow Monitor according to our recommendations, see Figure 1.

Under the above section 3.1 it is described how the Monitor creates the differential pressure. Eletta Flow Monitors work with two different ΔP 's i.e. on the V1C units the ΔP is always maximum 2000 mm H₂O (196 mbar) and for the V15C units, the ΔP is always maximum 5500 mm H₂O (539 mbar). This means that at maximum ΔP the flow is always 100% in any Flow Monitor mounted on any pipe section. This makes it very easy to move one control

unit from one pipe to another pipe section on another pipe in order to check the function. It does not matter what size/diameter the pipe section has, as we always work with the same ΔP on every pipe size and corresponding Control Unit.

You can of course also verify the alarm point in the Eletta Flow Monitor versus another flow meter in the system or take the Monitor out and put in a flow test rig, if you have the possibility.

If the above is not the case there is a need to send the Monitor to the Distributor or directly to The Eletta Service department for control.

If you find process liquid/gas coming out of the Control Unit;

Most probably you will find a broken diaphragm lever, the small stainless steel shaft going through a rubber sealing and it is attached to the diaphragm in the end. If you have exposed the Monitor to excessive pressure (over 16 bar/232 PSI standard) or if the process liquid/gas is too aggressive to the rubber in the sealing, it can cause the sealing to break.

When this happens, it nearly always brakes the micro switches and therefore you will need to replace the whole Control Unit as this is a from the manufacturer calibrated replacement part.

Please check the identification plate/tag on the Monitor and write down the serial number, flow range and liquid before ordering a new Control Unit from your representative or us. You can then easily replace the broken Control Unit in minutes without any field calibration necessary (*please section 2.5 for details on how to replace a Control Unit*).

If you originally ordered a specially designed Flow Monitor i.e. if it does not follow our standard execution, it must be checked what kind of soft parts (diaphragm and seals) you have installed in the Flow Monitor. There are three different kinds of rubber to order (*see section 1.2 for details*) and we kindly ask you to provide us with the above information in order to help us ship you the right material.

4.2 Electrical connections

Please always see to that you are using the right voltage and current (*see Specification section 1.2*) and that you have connected all the leads in a proper way (*see section 2.7*). If you remove the cover on the Control Unit of the Monitors it is normally very easy to see if a component is broken/burned.

If so, please do not try to repair the unit yourself. Check the identification plate/tag and write down the serial number, flow range and liquid and order a new Unit from us.

We will ship you the complete Control Unit with diaphragm housing and you then can easily fit the new Control Unit to your existing Pipe Section with only four (4) screws, (*please see section 2.5 for details*).

4.3 Spares

We are proud to say that our Flow Monitors are well known for their long life-time and robust construction but inevitably, it is sometimes needed to order spare parts. We refer to section 7 where you can find an exploded drawing showing all replaceable components included in the Flow Monitor.

Tables

5.1 Measuring Ranges

V2		
Dim. DN		lit/min
1/2" ON15	GL,GSS FA, FSS	0,4 - 0,8
		0,6 - 1,2
		1 - 2
		1,6 - 3,2
		2 - 4
		2,4 - 4,8
		3,2 - 6,4
		4 - 8
		6 - 12
		B - 16
3/4" DN20	GL,GSS FA, FSS	4 - B
		6 - 12
		8 - 16
		10 - 20
		12 - 24
		16 - 32
1" ON25	GL,GSS FA, FSS	8 - 16
		10 - 20
		12 - 24
		16 - 32
		24 - 48
		36 - 72
FA, FSS	40 - 80	
	50 - 100	
1 1/4" ON32	FA, FSS	20 - 40
		28 - 56
		40 - 80
		60 - 120
11/2" ON40	GL, FA, FSS	20 - 40
		28 - 56
		40 - 80
		60 - 120
		80 - 160
FA, FSS	100 - 200	
2" DNSO	FA, FSS	40 - 80
		60 - 120
		80 - 160
		120 - 240
		160 - 320
2 1/2" DN65	FA, FSS	60 - 120
		80 - 160
		120 - 240
		160 - 320
		240 - 480
3" ONSO	FA, FSS	120 - 240
		160 - 320
		240 - 480
		320 - 640
		400 - 800
4" DN 100	FA, FSS	160 - 320
		280 - 560
		400 - 800
		600 - 1200
		700 - 1400
5" DN 125	FA, FSS	400 - 800
		600 - 1200
		800 - 1600
		1000 - 2000
6" DN 150	FA, FSS	600 - 1200
		800 - 1600
		1200 - 2400
		1400 - 2800
		1500 - 3000
8" DN200	FA, FSS	800 - 1600
		1200 - 2400
		1600 - 3200
		2400 - 4800
		2500 - 5000
10" DN250	FA, FSS	1600 - 3200
		2000 - 4000
		3200 - 6400
		4000 - 8000

V25		
Dim. DN		lit/min
1/2" DN15	GL,GSS FA, FSS	0,4 - 2
		1 - 5
		2 - 10
		4 - 20
		6 - 30
3/4" DN20	GL, GSS FA, FSS	4 - 20
		B - 40
		15 - 75
1" DN25	GL, GSS F, A FSS	6 - 30
		12 - 60
		16 - 80
		24 - 120
FA, FSS	30 - 150	
1 1/4" DN32	FA, FSS	B - 40
		20 - 100
		40 - 200
50 - 250		
11/2" DN40	GL, FA, FSS	8 - 40
		20 - 100
		40 - 200
2" DN 50	FA, FSS	60 - 300
		20 - 100
		40 - 200
		70 - 350
100 - 500		
2 1/2" DN 65	FA, FSS	20 - 100
		50 - 250
		100 - 500
160 - 800		
3" DN 80	FA, FSS	40 - 200
		80 - 400
		160 - 800
		240 - 1200
4" DN 100	FA, FSS	80 - 400
		160 - 800
		250 - 1250
		400 - 2000
5" DN 125	FA, FSS	100 - 500
		200 - 1000
		400 - 2000
		600 - 3000
6" DN 150	FA, FSS	200 - 1000
		400 - 2000
		600 - 3000
		900 - 4500
8" DN200	FA, FSS	400 - 2000
		600 - 3000
		1000 - 5000
		1500 - 7500
10" DN250	FA, FSS	600 - 3000
		1000 - 5000
		1600 - 8000
		2400 - 12000

It is possible to order a lower measuring range than indicated in the table above for each pipe size, but not a higher one.

6.1 V2/V25-GL/FA

Pos.	Description	Qty	Pos.	Description	Qty
1	Cover	1	31	Flange gasket	2
2	Screw	4	32	Flow direction selector	1
3	Microswitch	2	33	Connecting unit, FA	1
4	Spring bar	1	34	Screw	2
5	Screw	2	35	O-ring	2
6	Screw	2	36	Screw	4
7	Screw	2	37	Flange threaded, GL	2
8	Locknut	2	38	O-ring	1
9	Cable gland	1	39	Pipe body GL	1
10	Mounting plate	1	40	O-ring	2
11	Casing	1	41	Orifice plate	1
12	Screw	1	42	Spacer -GL	1
13	O-ring	2	43	Nut	4
14	O-ring	1			
15	Lever	1			
16	Diaphragm housing	1			
17	Screw	4			
18	Diaphragm	1			
19	Diaphragm spring	2			
20	Diaphragm cover	1			
21	Washer	9			
22	Screw	9			
23	Pipe body, -FA	1			
24	Arrow	1			
25	Screw	1			
26	O-ring, orifice-plate	1			
27	Orifice plate, -FA	1			
28	Spacer, -FA	2			
29	Washer	4			
30	Screw	4			

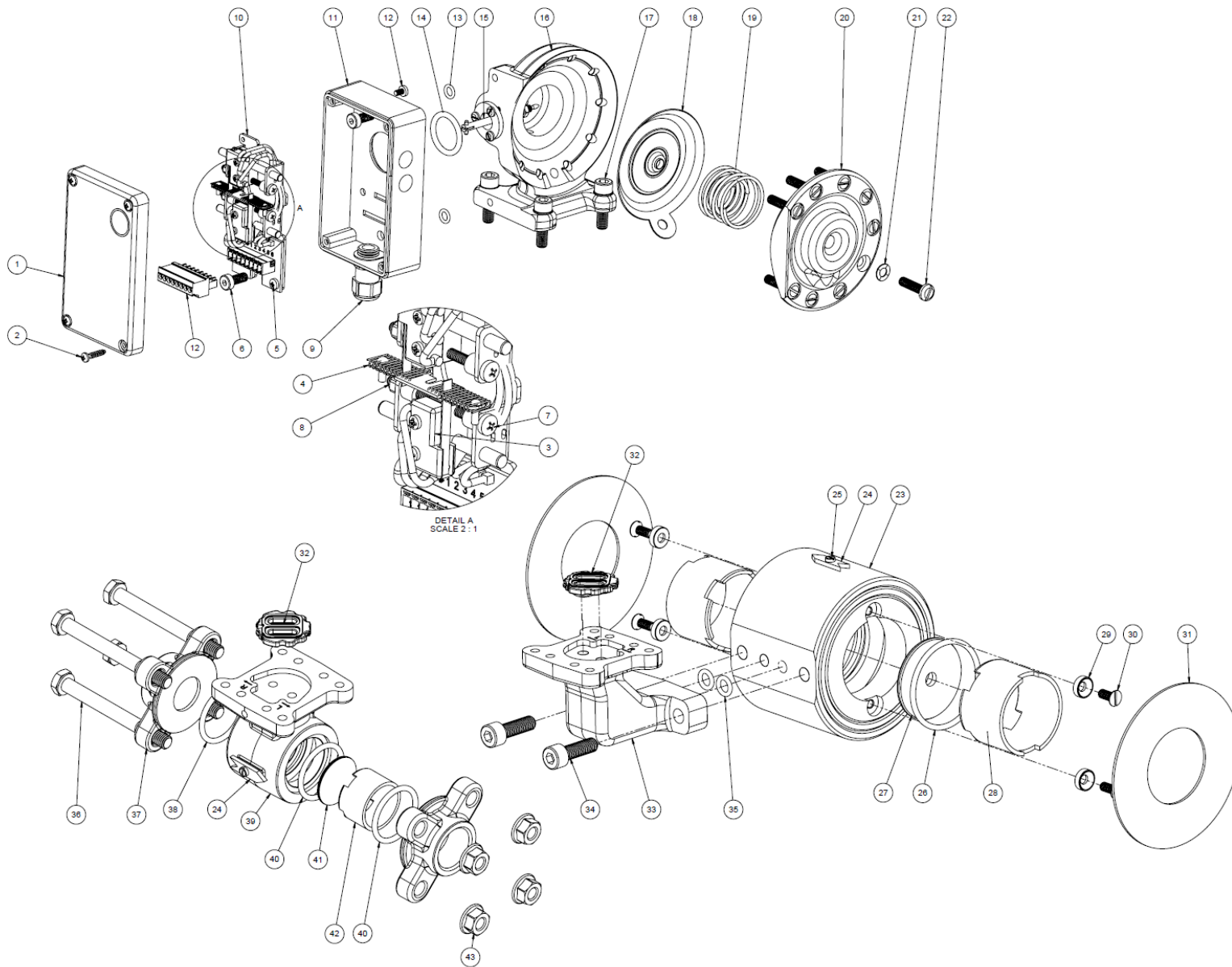

Pos.	Description	Qty	Pos.	Description	Qty
1	Cover	1	16	Diaphragm housing	1
2	Screw	4	17	Diaphragm	1
3	Microswitch	2	18	Diaphragm spring	2
4	Spring bar	1	19	Diaphragm cover	1
5	Screw	4	20	Spring washer	6
6	Screw	2	21	Screw	6
7	Locknut	2	22	Screw	4
8	Cable gland	1	23	Pipe connection	2
9	Screw	2	24	O-ring	2
10	Mounting plate	1	25	Pipe body GSS	1
11	Casing	1	26	O-ring	1
12	Connection box	1	27	Orifice plate	1
13	O-ring	2	28	Spacer GSS	1
14	O-ring	1	29	Nut	4
15	Lever	1	30	Screw	2
			31	Pipe body FSS	1
			32	Gasket	2

V2/V25-GSS/FSS

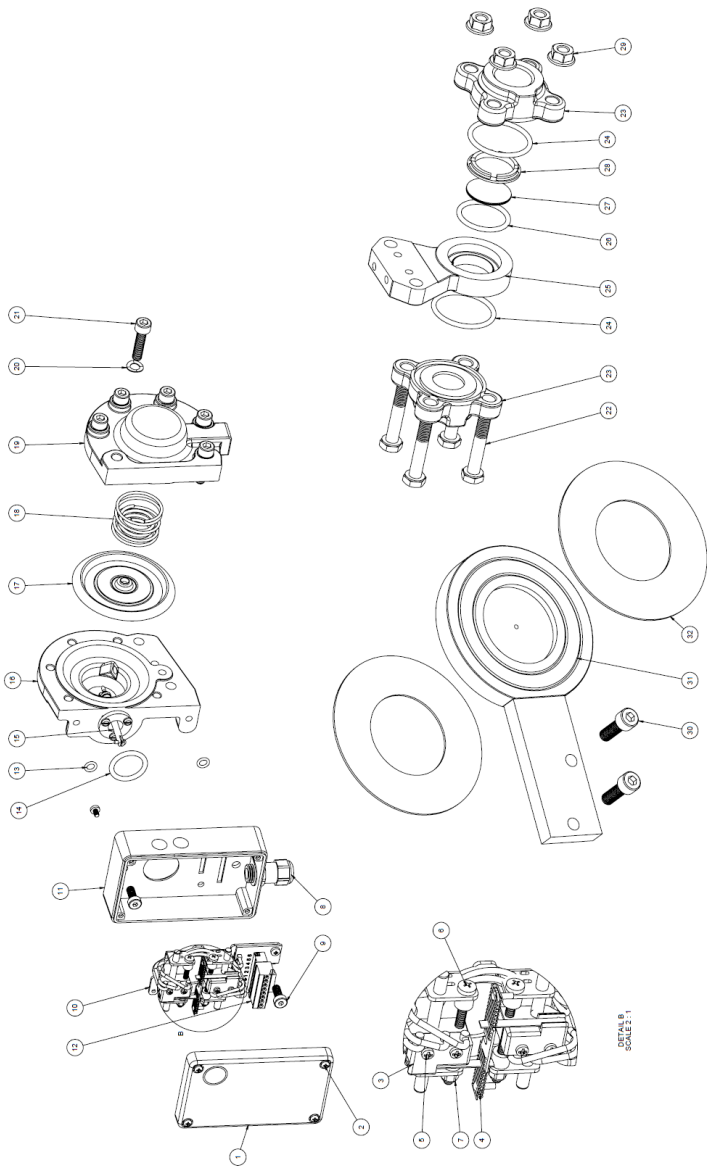

SAUER
SCHAUBL

Distributors

Eletta has appointed distributors around the world. You find more information about which distributor to contact on our website www.eletta.com or call our customer service.

Phone: +46 8 603 07 80

Recycling

Recycle your product and packing.



These products and packaging should not be mixed with general household waste. For proper recycling, please take these products to a designated collection point where they will be accepted free of charge. Please contact your local authority or your household waste disposal service for further details of your nearest designated collection point. Penalties may be applicable for incorrect disposal of this waste, in accordance with your national legislation.

Correct product disposal saves resources and prevents negative effects on human health and the environment.

ELETTA