

Manual Eletta Flow Monitor TIVG-series



About this manual

- This manual relates to the TIVG-series Flow Monitor.
- Note that the latest version of this manual is always available as a PDF file on our web site www.eletta.com.
- On our site you will find other interesting information such as our product configurator where you can build your own Monitor, leaflets, certificates etc.

Proprietary Rights

This manual contains confidential technical data, including trade secrets and proprietary information, that are the property of Eletta Flow AB, Sweden. Any changes or alterations to downloaded or printed Eletta original documentation such as manuals, drawings, leaflets, etc, are not permitted without a written permission from Eletta Flow AB, Sweden.

These data are only disclosed to you under permission of limited use within your company. Use for manufacturing or processing is not permitted.

Any other use of data and information is strictly prohibited without prior written permission from Eletta Flow AB, Sweden.

Distributors

Eletta has appointed a number of distributors all over the world. You will find more information about your closest distributor at our web site www.eletta.com, or by contacting our Customer Service Center.

Contact

Orders/inquiries: +468 603 07 80
Switchboard: +468 603 07 70

E-mail: info@eletta.com
Web: www.eletta.com

Address: Eletta Flow AB
P.O Box 5084
SE-141 05 Kungens Kurva
Sweden

Contents

1	General Information	4
1.1	Description	4
1.2	Specifications	5
2	Installation	7
2.1	Unpacking	7
2.2	Procedures before Installation	7
2.3	Installation of the Pipe Section	7
2.4	Installation and changing the Control Unit.....	9
2.5	Electrical Installation	10
3	Operation	11
3.1	Principle of operation, DP-Flow Measurement.....	11
3.2	Change of Flow Range	11
3.3	Adjustment of switch point, S2 and S25.....	13
3.4	Change of Flow Direction	14
3.4.1	Flow Direction Selector	14
3.5	Change of Dial Orientation	15
4	Trouble shooting	16
4.1	Verification of Flow	16
4.2	Electrical connections	17
4.3	Spares.....	18
5	Tables	19
5.1	Measuring Ranges.....	19
5.2	Weight and Dimensions TIVG V15R	20
	Weight and Dimensions TIVG S25R.....	21
	Weight and Dimensions TIVG S25F	22
6	Spare Parts	23
6.1	Exploded Drawing TIVG-V15-15 and 25R.....	23
6.2	Exploded Drawing TIVG-V15-40R	24
6.3	Exploded Drawing TIVG-S25-15 and 25 R.....	25
6.4	Exploded Drawing TIVG-S25-40R	26
6.5	Exploded Drawing TIVG-S25F	27
7	Distributors	28
8	Recycling	28

General Information

1.1 Description

The Eletta Flow Monitor is used to control and measure flow of liquids in pipes from size 15 mm to 400 mm (larger pipes as an option). They have been manufactured for over 70 years and are well known for its reliability. They are used where operational safety demands, efficient supervision and rugged installation is needed, all over the world. Eletta Flow AB in Sweden is certified according to ISO9001 and ISO14001 and certified by the nuclear industry in several countries.

The Eletta TIVG-series is replacing the old TIVG-F and -R series with updated materials and functions. The upgrade gives a higher quality indicator allowing a higher flow rate and wider flow turndown.

The Eletta Flow Monitor is based on the proven and dependable differential pressure principle, using interchangeable orifice plates for different measuring ranges. The Flow Monitors are working a different differential pressure range of 22 – 550 mbar depending on the desired and ordered flow range.

The Instrument consists of two parts mainly i.e. the Pipe Section and the Control Unit. The Pipe Section is the part that is to be mounted in the process pipe and the Control Unit is mounted directly (standard) or remote on/to the Pipe Section. The Control Unit is giving you the Flow information and also contains all electrical connections for input and output.

The Pipe Sections are available in different process connections with the following standards;

Threaded connections in BSP from 15 mm (1/2") to 40 mm (1 1/2").

Flanged (wafer) connection from DN15 - 200/PN16. DN250 - 400 PN10.

The Control Units type TIVG-V15 series has an indicating window which indicates roughly how the flow is which makes it easy to check if there is a flow or not. The TIVG-V15 has one SPDT microswitch settable within the chosen measuring range. This is replacement for TIVG-R series with one microswitch.

The Control Units type TIVG-S has a local readout and are also equipped with two independent adjustable alarms (micro switches) which can be set for low and high flow alarm. This is replacement for TIVG-F. The scale goes from **1** to **5** and hence, this is the value you use together with the multiplier at the bottom of the scale, to read the actual Flow through the

Monitor. As an option you can order a direct reading scale in different measuring units i.e. m³/h, l/min etc.

1.2 Specifications

Accuracy: <+/-5% F.S (full scale) of the chosen Flow range

The accuracy stated is achievable if the installation instruction is followed given in this manual. It is recommended that you always choose the Flow Range of the Flow Monitor so that the normal flow is in the middle of the Monitor Flow Range. Make sure that the expected alarm set points are within the chosen flow range.

Repeatability: < 2 % actual

Pressure: Max:16 bar PN16, DN250-400 10 bar PN10.
Min: Line pressure of apx.: 0,7 – 1,0 bar (10 – 14,5 PSI) is required for proper operation.

Temperature: Control Unit
-5°C to 90°C standard
-20°C to 90°C only for DN40 threaded version

Indicating window (TIVG-V15):
Acrylic.

Dial TIVG-S25 120 mm diameter with mechanical pointer and a linear scale.

Front glass: PC, Polycarbonate.

Process connection: DN15, 25 and 40 BSP threaded
DN15 – 400 flanged (wafer)

Alarm/

Contacts: TIVG-V15 has one micro switch SPDT contact.
TIVG-S25 has 2 (two) micro switch SPDT contacts, independently adjustable within the ordered flow range.

Micro switch spec:

Contact surfaces are silver plated as standard.

- Hystereses: 10%
- Rated voltage: 480 VAC/15A
- Breaking current: 15@125, 250, 480 VAC
- Resistive load: 2A@30 VDC
4A@125 VDC
0,2A@230 VDC
- Type: SPDT

Enclosure: IP65 (NEMA 4x)

Electrical terminal: Ceramic

Indicating unit: Powder coated aluminum alloy

Wetted material:

- Stainless steel units: Stainless steel 316L /1.4404
- Brass unit DN40: Dezincification hardened brass CW602N, EN12420

Rubber parts: For stainless steel units Fluorinated rubber FPM and for brass unit (DN40) Nitril HNBR

Spacer G40 only: The spacer that holds the orifice plate inside the pipes section and they are made of Polyamide plastic (PA) as a standard. Max.liquid/gas temperature is 150°C (300°F).

CE-approvals:

The Eletta Flow Monitors conforms with the EU directive for low voltage no: 72/23/EEC (EN 60 204-1, Part 1.) We refer to the certificates issued, which will be sent to you upon request. They are also available at www.eletta.com.

PED-Directive:

Complies with applicable parts in Pressure Equipment Directive 2014/68/EU. Conformity assessment has been performed according to module A. Internal production control combined with module A2. Internal manufacturing checks with monitoring of the final assessment, for category 2. Performed by Kiwa Inspecta. PED Declaration of conformity will be sent to you upon request and are also available on www.eletta.com.

2.1 Unpacking

We appreciate that you have decided to purchase our Products and we would like to ask you to begin the installation by checking your delivery against the Packing List. Please make sure to check the box for external damages before opening. If you find external damages, which have also led to damages to the Flow Monitor inside, you should contact the forwarder/shipper to claim replacement (or the cost of replacement). Check the Monitors' identification tag against your purchase order to make sure you have got the right parts with the right specifications.

All Monitors are individually packed in a carton. The box is made from recycled environmental friendly material and we kindly ask you to deal with the waste material in a way that will have as little impact on the environment as possible.

2.2 Procedures before Installation

Note!!! Before any installation or maintenance work, disconnect all electrical power!

Please check that you are going to mount the Monitor at the lowest point in the piping system if you are measuring liquids and at the highest point if you are measuring gases. Also check if the planned flow direction in the system matches the one indicated on the Monitor.

Check that the pipe section has the right threads or the right flange standard to match your piping or counter flange.

2.3 Installation of the Pipe Section

Note!!! Before starting to install the Pipe Section, please make sure that the piping is not under pressure from flow of liquid/gas!

The pipe section can be installed in any desired direction, vertically or horizontally or angular and the direction arrow on the pipe section denote the direction of the flow. It is very important that the pipe section is mounted with the correct direction, as the function of the Flow Monitor otherwise will be prevented. The piping shall be rigid and free from vibrations and hoses connected directly into the Monitors should be avoided as much as possible. The straight runs before and after the Monitor should not be too short, in order to avoid disturbances, which can cause the Monitor to show incorrect values. We recommend giving at least 10 - 15 diameters up- stream and 5 diameters downstream. (Please see Fig. 1)

Recommended installation of Pipe Section

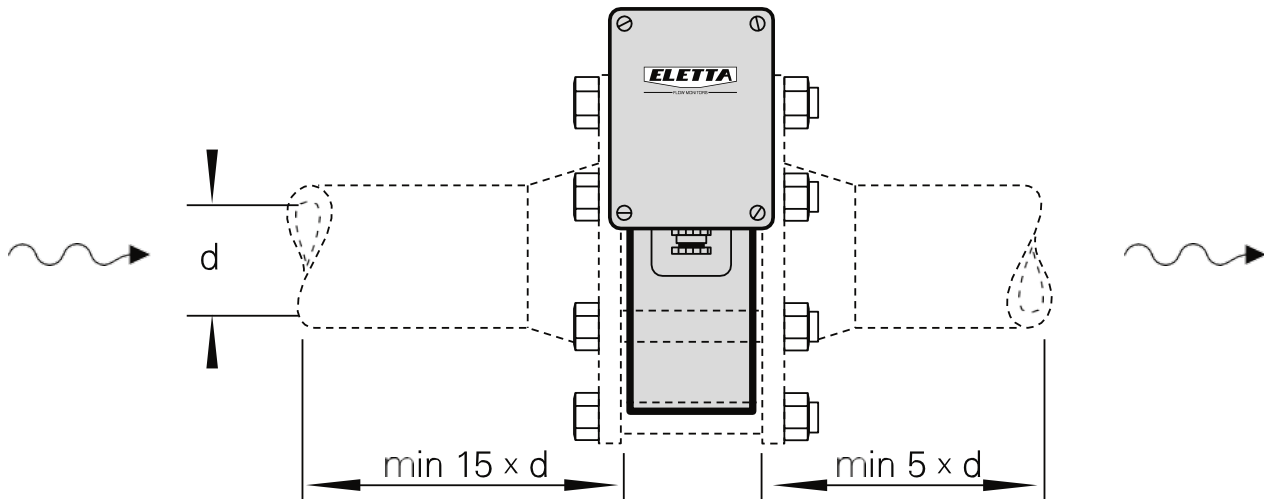

Figure 1

The reasons for this procedure is to achieve a stable flow profile inside the pipe and by doing so, get a true reading. Please be aware of the fact that it is practically impossible to predict when the flow is stable after disturbances in the piping, so this must serve as a guideline only. The straight runs must be free from valves, bends or in/decreasing diameters. Any of these disturbances must be placed **before** and preferably **after** you start counting the straight runs.

If you are installing the threaded version, please make sure that you are not using so called **"tube fittings"**. We have often seen them to have a much smaller inside diameter than the pipe section, even though the size of the thread match. This can create a jet stream of the fluid/gas, which will cause the differential pressure to be too low and you will not get a good or accurate reading.

The following inside diameters apply for the threaded Pipe Sections:

Threaded stainless steel DN 15 = **16 mm**

Threaded stainless steel DN 25 = **26 mm**

Threaded brass DN40 = **41 mm**

Make sure that the Control unit, if mounted directly on the Pipe Section, is placed on top of the Pipe Section and not under to prevent particles in the fluid to collect in the diaphragm housing. Please use a filter in the pipeline if you suspect the fluid to contain particles.

The flanged models must be aligned with the counter flange and not placed in stress by tightening the bolts uneven. The flanged models come with a gasket and we recommend using this, as it is dimensioned to suit the installation. Please see to that the gasket is properly aligned and not disturbing the flow. It is also of outmost importance that the connecting pipe and flange is of the same diameter (inside) and standard as the pipe section. A mismatch can cause an erratic or incorrect reading of the flow. If needed, please support the Flow Monitors with rigid brackets. There is no problem in attaching the brackets directly to the Flow Monitor, but we recommend mounting them in the pipeline downstream and upstream to avoid unnecessary stress in the installation area.

2.4 Installation and changing of the Control Unit

Start with making sure that there is no pressure in the system. Turn the electric power supply off and then disconnect the cables from the micro switch electric terminal.

On the Brass G40 Pipe Section; loosen the four (4) hexagon screws that hold the diaphragm housing (do not remove the blue housing at any time) to the Pipe Section. Replace the flow direction selector (3.4.1) if damaged, or if other material is required. Install the new Control Unit and tighten the four (4) hexagon screws firmly again.

On the threaded stainless steel Pipe Section; loosen the two (2) hexagon screws that hold the diaphragm housing and replace the O-rings to the right material, if necessary. Install the new Control Unit and tighten the two (2) screws firmly again.

On the flanged stainless steel Pipe Section; Loosen the four screws that hold the diaphragm housing and replace the flow direction selector (3.4.2) if damaged. Install the new Control Unit and tighten the four (4) screws firmly again.

Connect the electrical cables according to your new Control Unit's possibilities and for detailed information regarding wiring, please see section 2.5 Electrical installation".

As an option we have a manifold with shut-off valves, this enables you to dismount the control unit from the pipe-section during full operation.

2.5 Electrical Installation

Note!!! An authorized professional person should make all electrical installations.

Before you connect any cables, please make sure that you have the right power supply within the specifications (see section 1.2 “Specifications”).

All terminal block connections are to be made through the included cable gland PR22,5/PG16 (and please note that you can have two alternative mountings of the cable gland depending on what side you want to enter with the cables). The terminal block connections are described in fig.5 below. A grounding screw is to be found at the side of the terminal block.

Before any circuit is connected/disconnected, make sure that all power is off!

Wiring diagram for the TIVG-S25

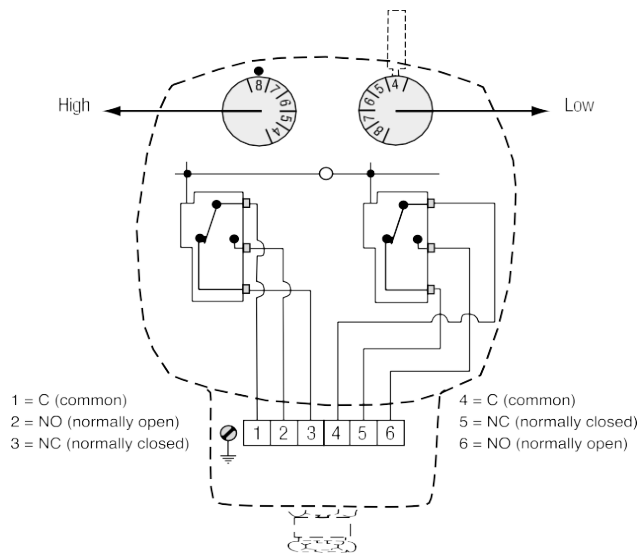

The wiring diagram shows the switching function when the flow is zero or below the lower setpoint.

Figure 5

Wiring diagram for the TIVG-V15

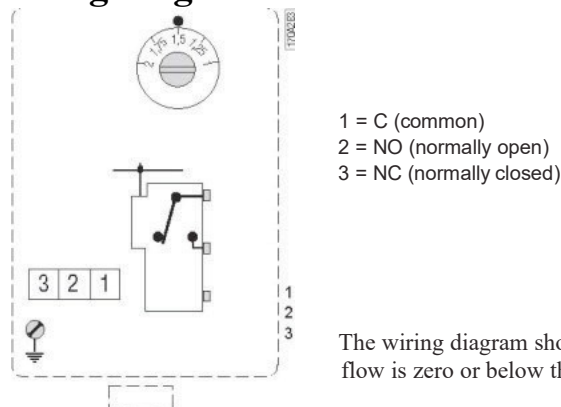

Figure 6

The wiring diagram shows the switching function flow is zero or below the setpoint.

Operation

3.1 Principle of operation, DP-Flow Measurement

The Eletta Flow Monitor's function is based on the proven and dependable differential pressure principal, using interchangeable sharp-edge orifice plates for different measuring ranges. This is perhaps the oldest and most widely used principle for flow metering, mainly because of its simplicity, its relatively low cost and high volume of research data available for predicting the Flow Monitors behavior. In the Pipe Section, a fixed area flow restriction (the orifice plate) causes a pressure drop, which varies with the flow rate. This pressure drop has a high and a low pressure, which is lead through two channels from each side of the orifice plate, to the Control Unit. By measure the pressure drop allows flow rate measurement by means of a mathematical formula. A short form of the calculation can be described as $Q=\sqrt{\Delta\rho}$.

In most Eletta Flow Monitors, the differential pressure is sensed and measured mechanically via a rubber diaphragm and linked to an outside of the process liquid/gas, mechanism. This mechanism transforms the movement into a Flow rate value shown on the dial. All Indicating units of the Eletta Flow Monitors are tested and approved according to the European CE-mark regulations. (Pls. contact your Distributor or Eletta Sweden for copy of certificate or go to www.eletta.com).

3.2 Change of Flow Range

The Eletta Flow Monitor features an orifice mechanism that does not require recalibration after replacement and can easily be rebuild in the field to change the flow range to another from the flow rate ordered. The orifice plate inside the pipe section is the only part in the liquid/gas that has to be changed. You can order and change any flow range that suits your specific application, as long as the new flow rate falls within the total possible span for the actual Flow Monitor (*see section 5.1*).

In each case of rebuilding the flow Monitor in the field, we kindly ask you to consult Eletta or your local Distributor for advise of the right orifice plate before ordering.

First empty the piping system so it is un-pressurized and has no flow!

For threaded model in Brass G40:

Untighten the bolts that hold the Pipe Section between the flanges in the piping (do not remove the threaded parts from the piping). Remove only the number of bolts necessary to pull the Monitor from the piping, normally it takes only one bolt from the highest position, to get the Monitor out. Take out the spacer that holds the orifice plate. Change the orifice plate to the new ordered orifice plate and remember that you can install it in any direction. Reinstall the spacer that holds the orifice in place inside the Pipe Section. Install the Monitor in the piping system again and tighten the bolts firmly to avoid leakage.

For threaded model stainless steel:

In this model there is no loose replaceable orifice plate and therefore it is necessary to change the complete orifice section with holder, to achieve a new flow range.

Please follow the above instructions for the brass model for dismounting the whole orifice plate with holder. Remove the Control Unit from the old Pipe Section (orifice section) and install this to the new Pipe Section. Remount the Flow Monitor into the piping system again and tighten the bolts firmly.

For flanged stainless steel model:

Loosen the Pipe Section from the counter flanges in the piping system. Take away the locking ring and the orifice plate. Install the new orifice-plate and locking ring and remount the Flow Monitor into the piping system again and tighten the bolts firmly.

Always check that no gaskets will interfere, by misaligning, with the flow when installing the Flow Monitor.

Type plate and measuring constant

When you change the orifice plate in order to get a new flow range, it is necessary to change the identification plate to a plate with the new range marked and for TIVG-S25 series also the measuring constant. This identification plate and constant must be specified separately on the order.

3.3 Adjustment of switch point

All the Indicating units on Eletta Flow Monitors are tested and calibrated according to the customers' orders before shipping. If the customer does not specify a desired switch point for the flow alarm, the TIVG-S25 Monitor's micro switches are preset to trip at the min- and max flow value. For the TIVG-V15 the micro switch is preset to trip at 50% (decreasing flow) of the ordered max flow value, for example a 10 - 20 l/min flow range would have the switch set to trip at 15 l/min, decreasing flow.

Please note!! We have calibrated each Indicating unit of the Flow Monitor in our flow rig and set the switches according to the Flow values we achieve in the rig under good conditions. We must stress that under actual field conditions, the flow profile can be different from the one in our flow rig depending on valves, hoses, bends or other obstructions and therefore the switching can be off from our preset values. There is a possibility to adjust the switch/alarm points in the field by adjusting the micro switches' position mechanically.

For TIVG-S25: To readjust, remove the two screws that hold the cover at the top of the blue housing. The two adjusting dials are then visible through the opening. Underneath the removed cover, you will find a small tool necessary to use in order to change the adjusting dials position.

The adjusting dials are marked the same as the scale in the front and this marking can be used to approximately find the right switch/alarm point for the actual application. Put the tool inside the drilled hole on the top of the adjusting dial and gently move the dial sideways to the desired position. If the two adjusting dials are set to the same position, the micro switches will trip at the same time. If possible, use the left adjusting dial for the high flow alarm (higher end of the scale) and the right for the min. flow alarm (the lower end of the scale), in order to get the best accuracy. If you use the alarms the other way around, the spring mechanism inside the diaphragm housing will be affected with lower accuracy as a result, so please try to avoid that. Repeat the procedure for the next adjusting dial and then put the tool back in its bracket at the cover.

Setting of high/low flow alarm for the TIVG-S25 (tool placed under top lid)

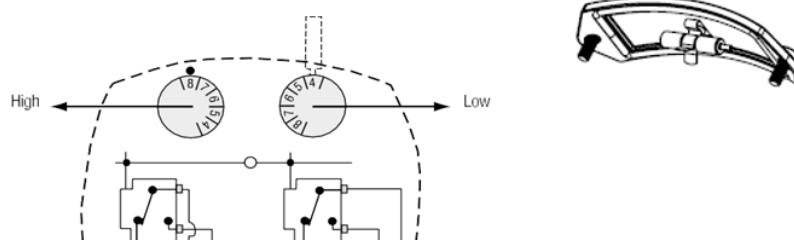

Figure 7

For TIVG-V15: To re-adjust, remove the cover and the adjusting dial is then visible at the top. Put a screwdriver in the slot of the adjusting dial and gently turn the dial to the desired position. You will find that you by doing this are moving the plate, where the micro switch is mounted mechanically.

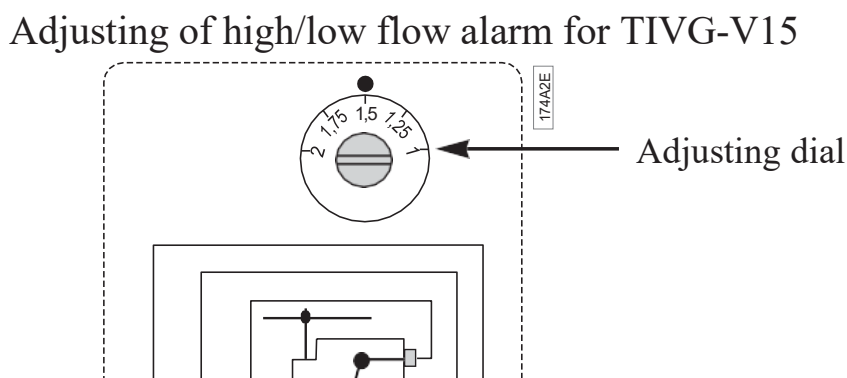

Figure 8

If you have the possibility to check against a flow meter in the system, you will get the best on site adjustment of the switch point.

Reinstall the cover at the top with the two screws and start up the process again.

3.4 Change of Flow Direction

Empty the pipe system so that it is un-pressurized and has no flow!

At the time of ordering, you must specify in which direction the Flow Monitor shall be mounted i.e. from which side is the flow entering the Pipe Section and how you would like to read the scale. (Please refer to fig. 6 below for alternatives.) If, for some reason, the Flow Monitor is ordered with the wrong flow direction, it is possible to change this in the field.

3.4.1 Flow direction Selector

The threaded brass version DN40 and the flanged stainless steel version are delivered with a flow direction selector that can be used for both directions. To change the direction, loosen the four (4) hexagon screw, which hold the diaphragm housing to the Pipe Section.

Remove the diaphragm housing and you will see the flow direction selector (it might have attached itself to the bottom side of the diaphragm housing). Replace the flow direction selector in the configuration for your system (see fig. 6).

Please also remember to turn the red arrow mounted on the Pipe Section only available on the brass threaded version G40.

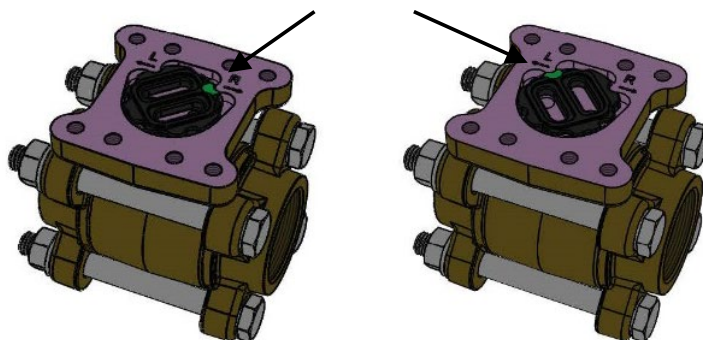

Figure 9

The green dot marks the chosen flow direction, R for right and L for left.

Change of the flow direction on our threaded Stainless Steel Pipe Sections is not possible in the field without ordering a new Pipe Section and we kindly ask you to contact your local representative or Eletta Flow AB, Sweden for help.

3.5 Change of Dial Orientation

As the Eletta Flow Monitors are not limited to a certain mounting position in the piping system, the large visible dial can be mounted in several positions to suit the application. (*please refer to fig. 7*). If you need to change the orientation in the field, please do as follows;

Note! Make sure that all electrical connections are set to power off before starting the following procedure!

Remove the front glass with the four screws that hold it in place. Push the pointer towards the dial and then upwards until the round hole in the pointer matches the spindle coming out from the mechanism and then remove the pointer. Undo the two screws that hold the dial and turn the dial 90° to the desired position and tighten the screws in the predrilled holes. Reinstall the pointer according to the new orientation with the reverse procedure from when it was removed.

Dial orientation and ordering code

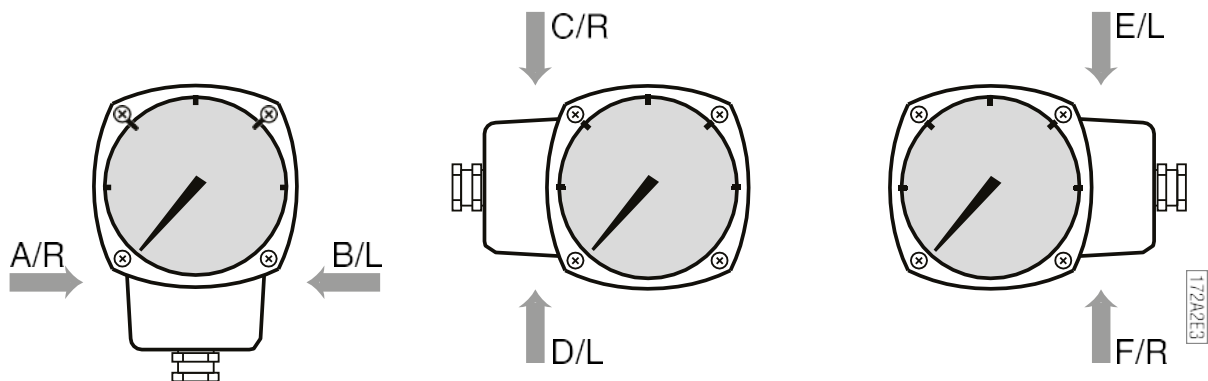

Figure 10

The spindle and the pointer has a square fitting which make s it possible to install the pointer in four (4) different positions and make sure that you put it firmly in the right position for your application. When there is no flow through the Monitor, the pointer shall point to the beginning of the red part of the scale = zero position.

Note that a change of the mounting direction of the dial also can make it necessary to change the flow direction selector (see section 3.4).

Trouble shooting

4.1 Verification of flow

We would like to stress the fact that all Indicating units on the Eletta Flow Monitors are calibrated and adjusted individually in water in a specially purpose built calibrated flow rig in our workshop. This means that we have calibrated/adjusted the Monitors under reference conditions with enough straight runs before and after, always the same liquid, temperature, flows and pressure. If you find our Monitors to show another value compared to a reference meter on site, it can well be due to the fact that the reference meter has been calibrated under other reference conditions and that our Monitor have other conditions on site in the actual application, than we used under the calibration prior to shipping.

The Monitor is not showing any or the wrong value:

Is the Monitor mounted correctly with respect to the flow direction? Please check the arrow on the outside of the pipe section with the actual (true) flow direction. For threaded version DN40 and stainless flanged -models, check the flow direction selector inside the monitor. Make sure that it is corresponding to the true flow, see 3.4.

Is there any flow in the pipe? And is it enough to create the needed $\Delta\rho$?

Do you have the right orifice plate for the application? Check the stamped values on the orifice plate. (pipe section model number and flow)

If you are using compression couplings into the Monitor inlet, check that the inside diameter is enough to avoid the “nozzle” effect described above in section 2.3 and also check the table for the minimum correct inner diameter in the same section.

Are there enough straight runs upstream and downstream the Monitor? (10 diameters upstream and 5 downstream.)

Do you have valves or bends in more than one plane within the above straight runs? If so, move the Monitor further away to achieve enough straight runs.

You can of course verify the flow in the Eletta Flow Monitor versus another flow meter in the system or take the Monitor out and put in a flow test rig, if you have the possibility.

If the above is not the case there is a need to send the Monitor to the Distributor or directly to The Eletta Service department for control.

If you find process liquid/gas coming out of the Control Unit;

Most probably you will find a broken lever, the small stainless steel shaft going through a rubber sealing and it is attached to the diaphragm in the end. If you have exposed the Monitor to excessive pressure (over 16 bar/232PSI standard) or if the process liquid/gas is too aggressive to the rubber in the sealing, it can cause the sealing to break.

Please check the identification plate/tag on the Monitor and write down the serial number, flow range and liquid before ordering a new lever from your representative or us.

4.2 Electrical connections

Please always see to that you are using the right voltage and current (*see section 1.2*) and that you have connected all the leads in a proper way (*see section 2.7*). If you open the cover on the Control Unit of the Monitor it is normally

very easy to see, if a component is broken/burned. If you find the micro switches are malfunctioning, it is possible to order new ones from Eletta Flow or your representative and replace them on site.

If you need to order a complete Monitor or a Control Unit for any reason, please check the identification plate/tag and write down the serial number, flow range and liquid and order a new Unit from us. We will ship you the complete Control Unit with diaphragm housing and you can then easily fit the new Control Unit to your existing Pipe Section with only four (4) screws, (*please see section 2.5 for details*).

4.3 Spares

We are proud to say that our Flow Monitors are well known for their long lifetime and robust construction but inevitably, it is sometimes needed to order spare parts. We refer to section 7 where you can find an exploded drawing showing all replaceable components included in the Flow Monitor.

Tables

5.1 Measuring Ranges

	"Old" TIVG-R	TIVG- SR	
	l/min	l/min	
Model	Actual range	TIVG-S threaded	MC x (S25)
15 R	0,2-6	0,2 -1	0,2
	0,4 - 1,2	0,3 - 1,5	0,3
	0,8-2,5	0,5-2,5	0,5
	1,6-4,8	1 -5	1
	3 - 9	2- 10	2
	5 - 15	4 - 20	4
	10 - 30	6 - 30	6
25 R	16-48	12-60	12
	24 - 72	16 - 80	16
	40-120	24-120	24
40 R	40-120	24-120	24
	70-210	50-250	50

	"Old" TIVG-F	TIVG-SF	
	l/min	l/min	
Model	Actual range	TIVG-S flanged	MC x (S25)
15 F	4,5 - 15	4-20	4
	9-20	5-25	5
	9-30	6-30	6
25F	15-50	10-50	10
	21-70	15-75	15
	30-100	20-100	20
40F	45-150	40-200	40
	60-200	50-250	50
50F	60-200	50-250	50
	90-300	70-350	70
65F	90-300	70-350	70
	150-500	100-500	100
80F	150-500	100-500	100
	210-700	160-800	160
100F	210-700	160-800	160
	300-1000	250-1 250	250
125F	450-1 500	400-2 000	400
	600-2 000	500-2 500	500
150F	600-2 000	500-2 500	500
	900-3 000	600-3 000	600
200F	1 200-4 000	1 000-5 000	1 000
250F	1 500-5 000	1 000-5 000	1 000
	1 800-6 000	1 200-6 000	1 200
300F	2 100- 7 000	1 500-7 500	1 500
	2 700-9 000	2 000-10 000	2 000
350F	3 600-12 000	2 400 - 12 000	2 400
400F	4 500 - 15 000	4 000 - 20 000	4 000

MC = Measuring constant
on TIVG-S25

5.2 Weight and Dimensions

TIVG-15 and 25R

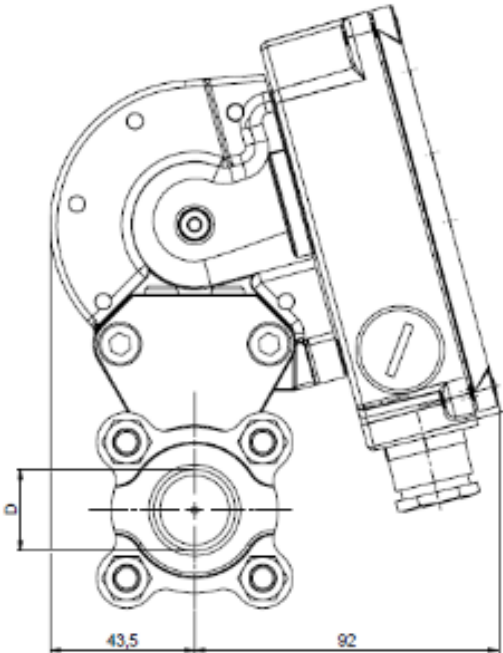
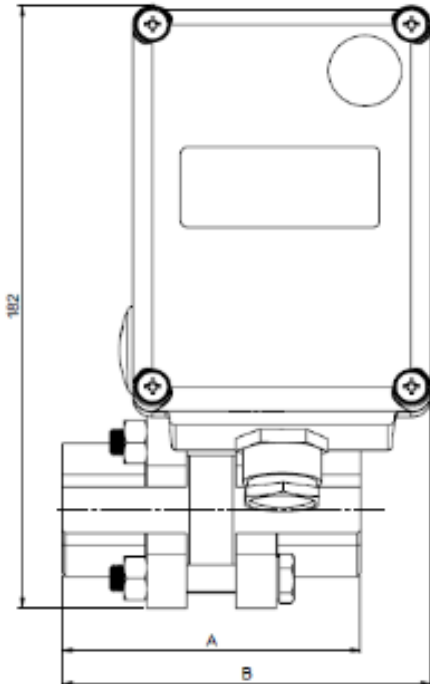

TIVG-V15-...R for threaded connection				
Nominal diameter	D Thread	A	B	Weight kg
DN15	G 1/2"	70	91	3,0
DN25	G 1"	90	111	3,0

TIVG-V15-40R

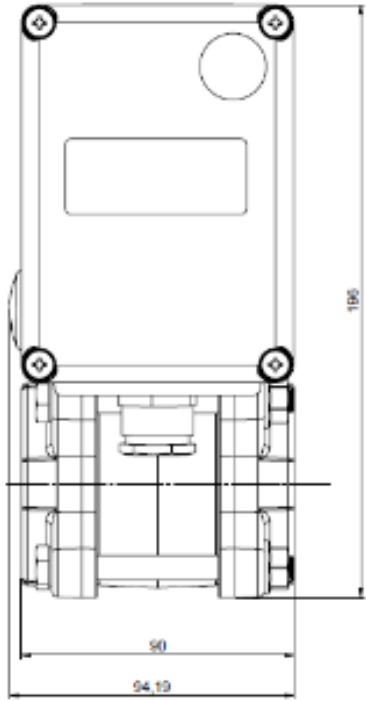

Weight 4,0 kg

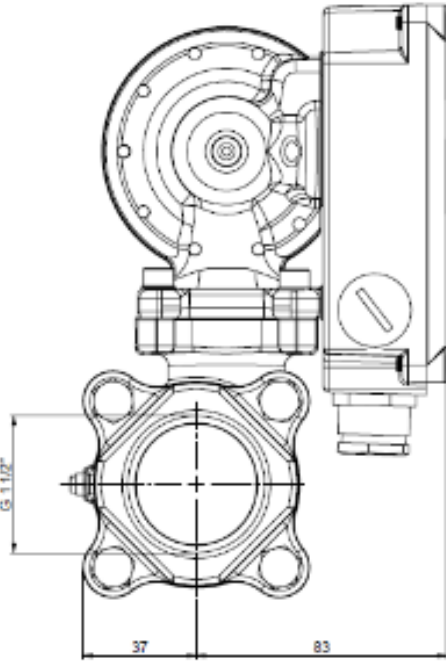

**TIVG-
S25-15 and 25R**

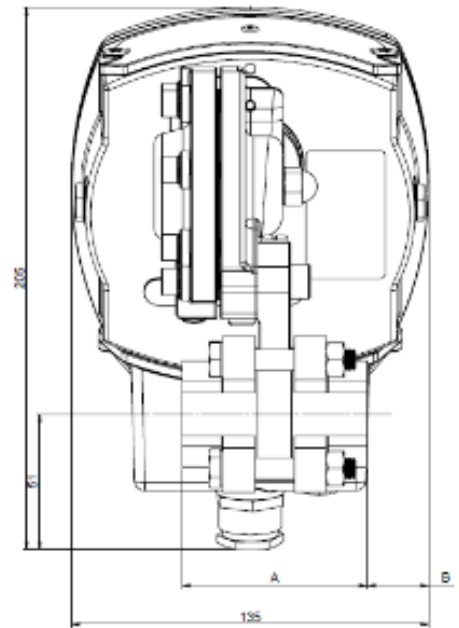
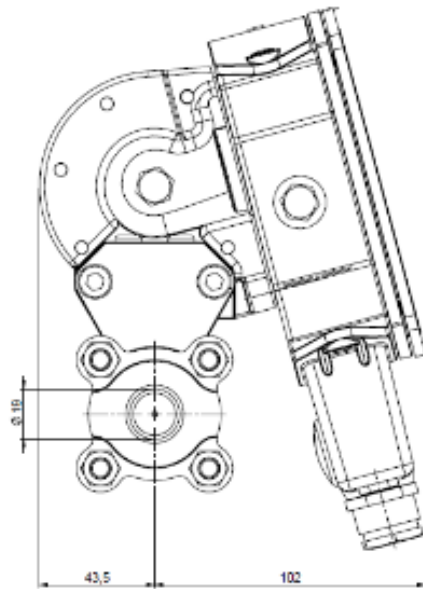

TIVG-S25-....R for threaded connection				
Nominal diameter	D Thread	A	B	Weight kg
DN15	G 1/2"	70	23	3,5
DN25	G 1"	90	33	3,5

**TIVG-
S25-40R**

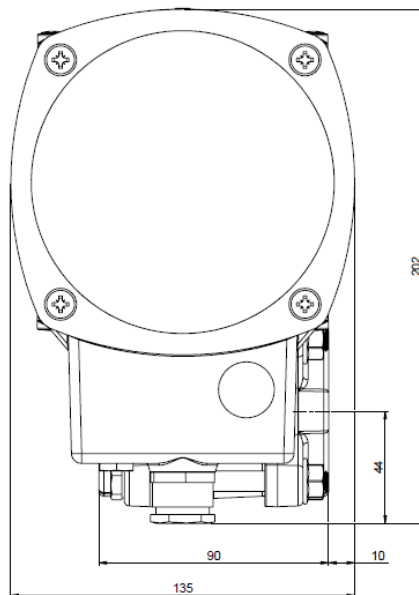

Weight: 4,4 kg

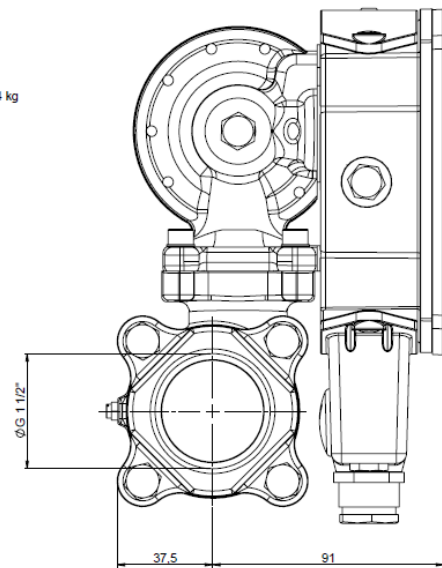

TIVG-S25F

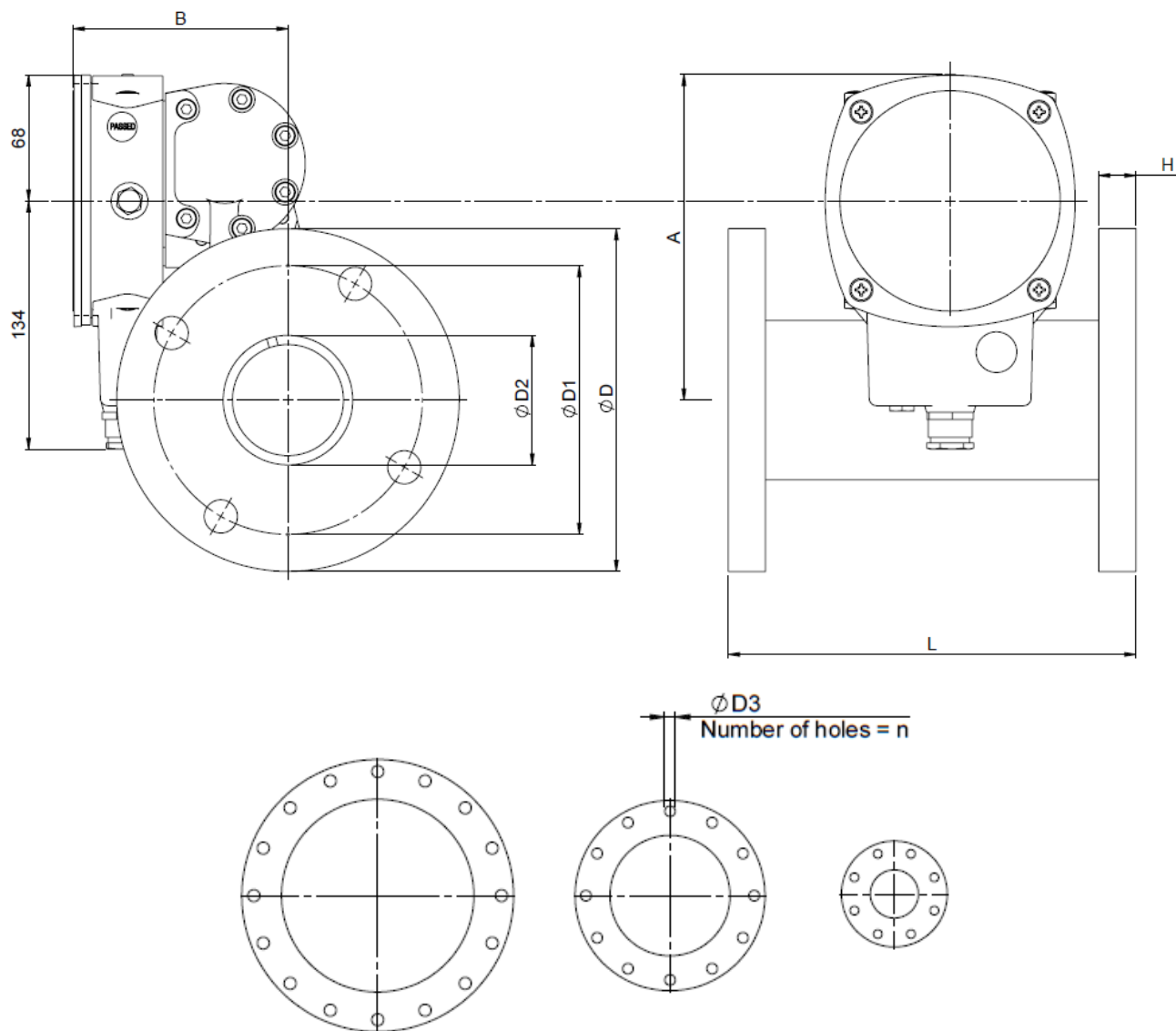

Type TIVG-S										
DN	A	B	D	D1	D2	D3	H	L	n	Weight kg
15	140	106	95	65	20	15	14	220	4	4,5
25	145	108	115	85	32	15	14	220	4	5,7
40	162	112	150	110	44	18	14	220	4	9,1
50	166	114	165	125	50	18	14	220	4	10,7
65	176	116	185	145	70	18	14	220	4	12,4
80	181	118	200	160	80	18	18	220	4 (8)*	14,1
100	194	121	220	180	100	18	18	220	8	18,7
125	206	124	250	210	125	18	18	220	8	22,4
150	216	131	285	240	150	22	18	220	8	26,5
200	237	155	340	295	200	22	20	220	8	37,3
250	258	172	395	350	250	22	22	220	12	40,4
300	277	200	445	400	300	22	22	220	12	49,7
350	302	216	505	460	350	22	30	320	16	78,7
400	320	228	565	515	400	25	30	320	16	86,8

* can be both acc to EN1092.1 = 8 holes or acc to ISO7005-1:2011 = 4 holes

6.1 TIVG-V15-15 and 25R

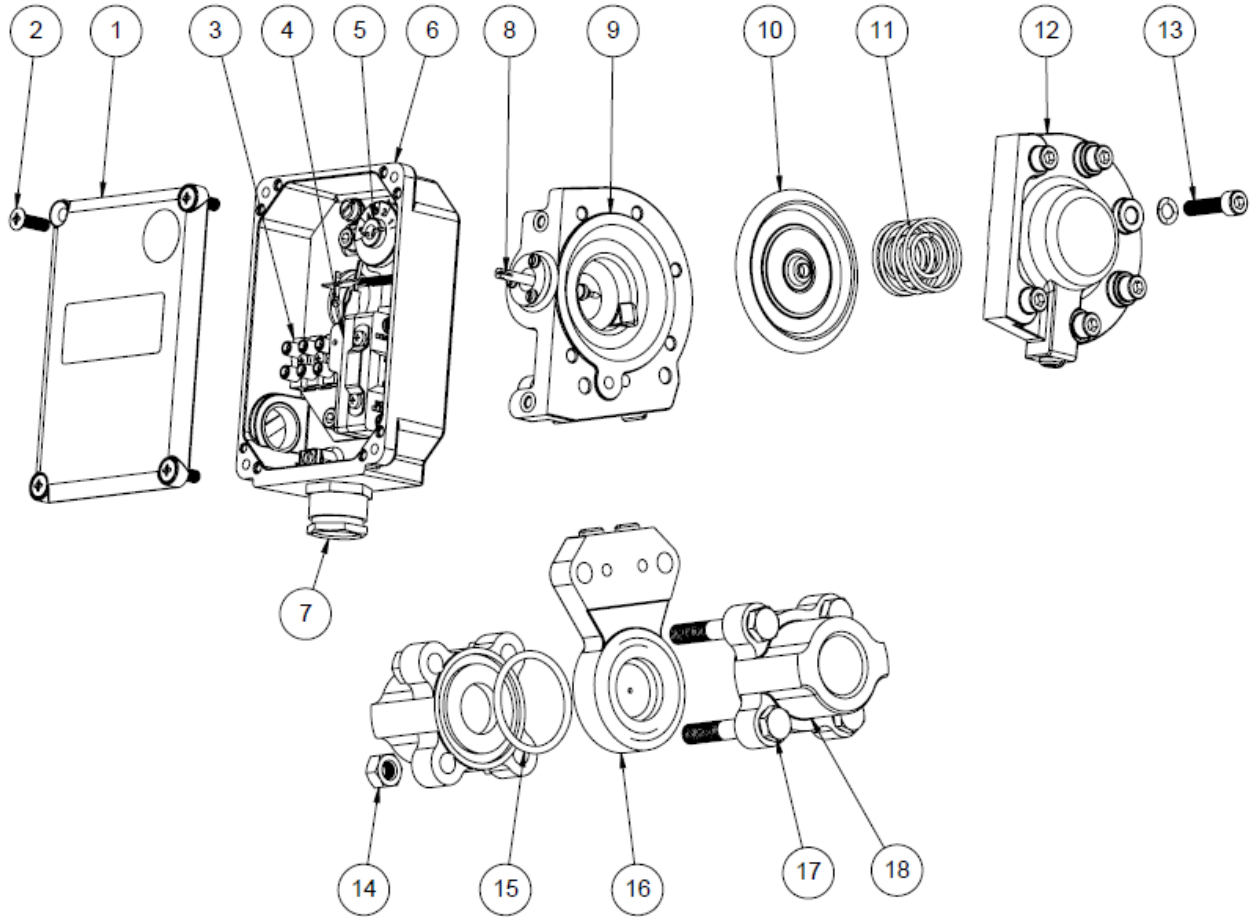

Item	Description	Qty
1	Cover	1
2	Screw	4
3	Terminal block	1
4	Microswitch	1
5	Adjusting dail	1
6	Casing	1
7	Cable gland	1
8	Lever	1
9	Diaphragm housing	1
10	Diaphragm	1
11	Diaphragm spring	1
12	Diaphragm cover	1
13	Screw with washer	6
14	Nut	4
15	O-ring	3
16	Pipe body GSS	1
17	Screw	4
18	Threaded Flange GSS	2

6.2 TIVG-V15-40R

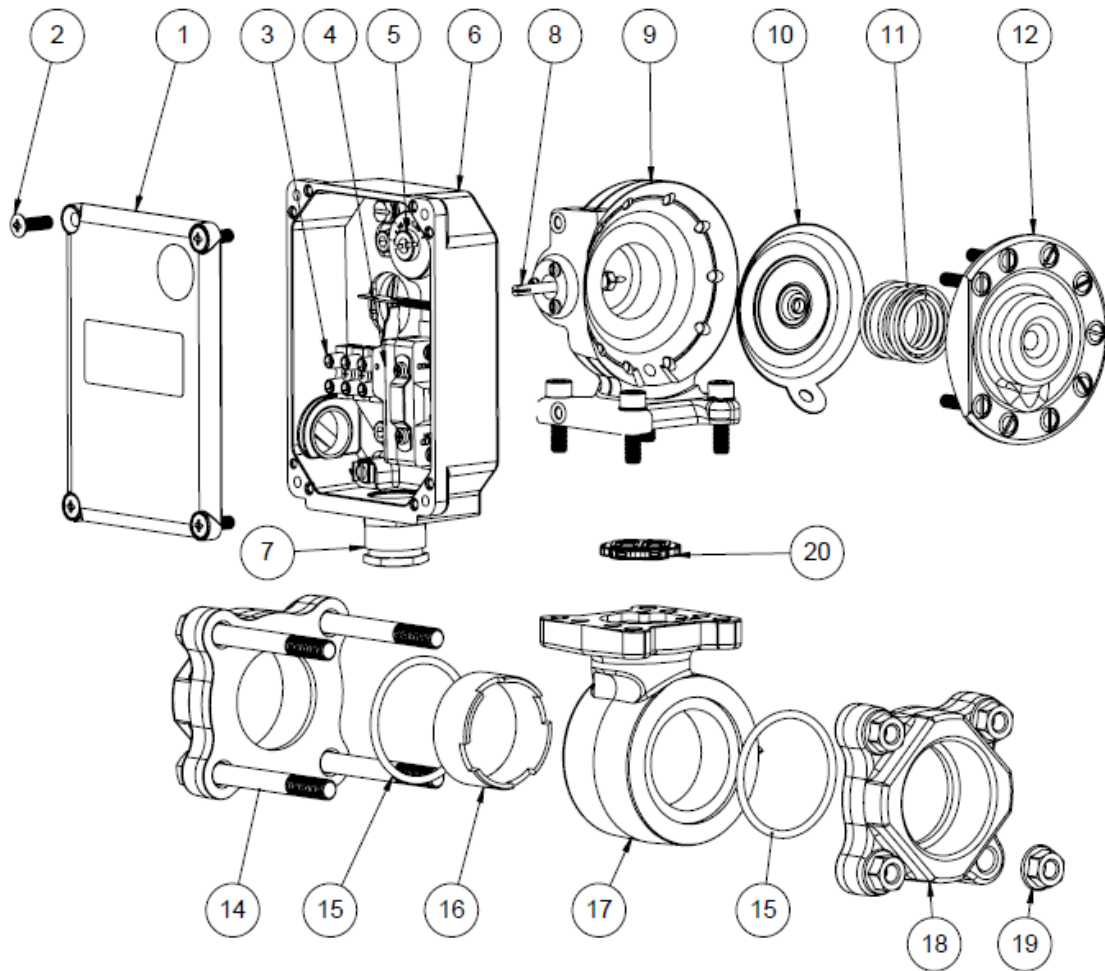

Item	Description	Qty
1	Cover	1
2	Screw	4
3	Terminal block	1
4	Microswitch	1
5	Adjusting dial	1
6	Casing	1
7	Cable gland	1
8	Lever	1
9	Diaphragm housing	1
10	Diaphragm	1
11	Diaphragm spring	1
12	Diaphragm cover	1
13	Screw with washer	6
14	Screw	4
15	O-ring	3
16	Spacer GL	1
17	Pipe body GL	1
18	Threaded Flange GL	2
19	Nut	4
20	Flow direction selector	1

6.3 TIVG-S25-15 and 25R

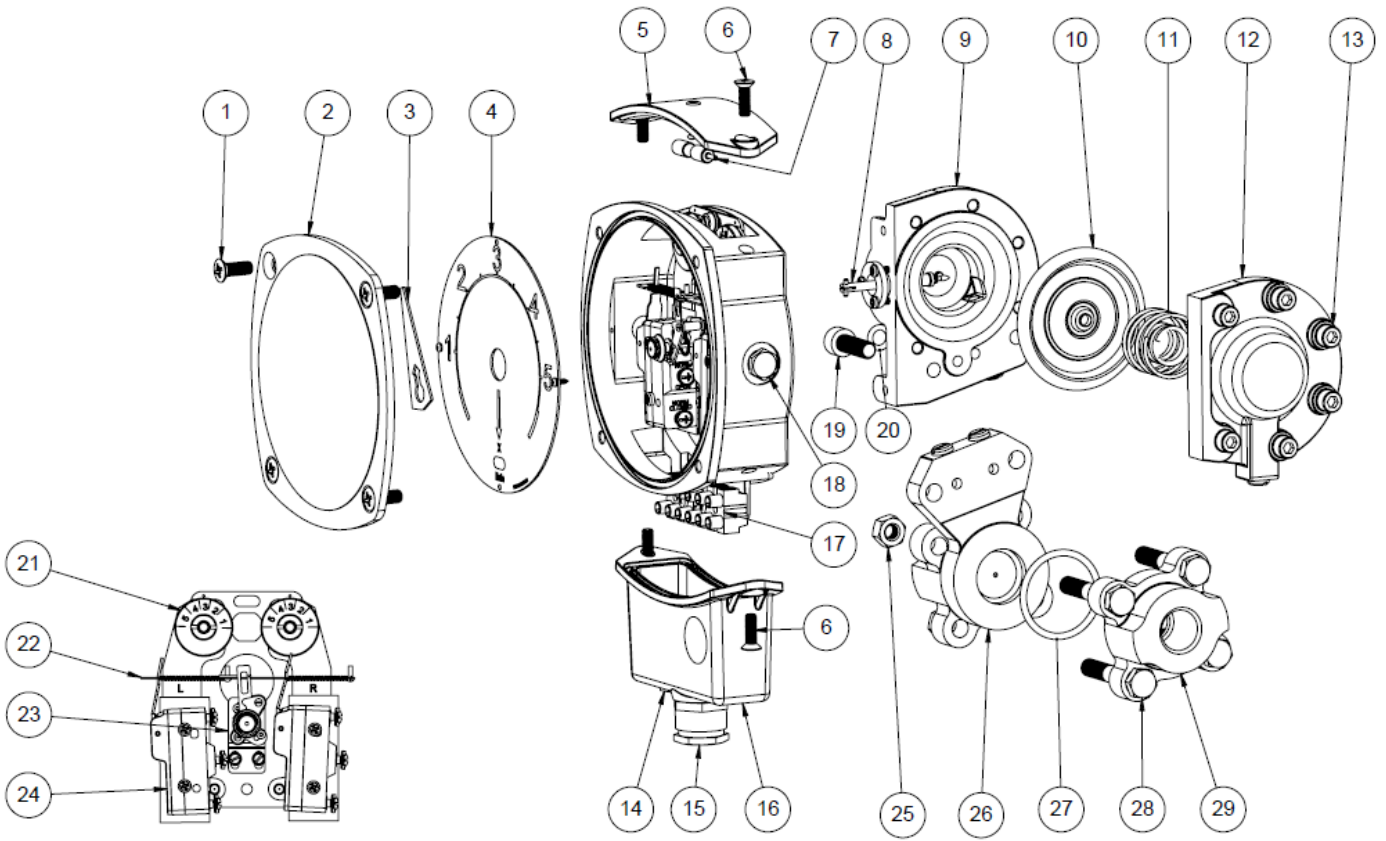

Item	Description	Qty
1	Screw	4
2	Dial glass	1
3	Pointer	1
4	Dial	1
5	Cover	1
6	Screw	4
7	Tool	1
8	Lever / rubber seal	1
9	Diaphragm housing	1
10	Diaphragm	1
11	Diaphragm spring	1
12	Diaphragm cover	1
13	Screw and washer	6
14	Fitting (Ventilation)	1
15	Cable gland Pg16	1
16	Connection box	1
17	Terminal block	1
18	Fitting	2
19	Screw	2
20	O-ring	2
21	Adjusting dail	2
22	Spring bar	1
23	Pointer mechanism	1
24	Microswitch	2
25	Nut	4
26	GSS Pipe	1
27	O-ring	2
28	Screw	4
29	Threaded Flange	2

6.4 TIVG-S25-40R

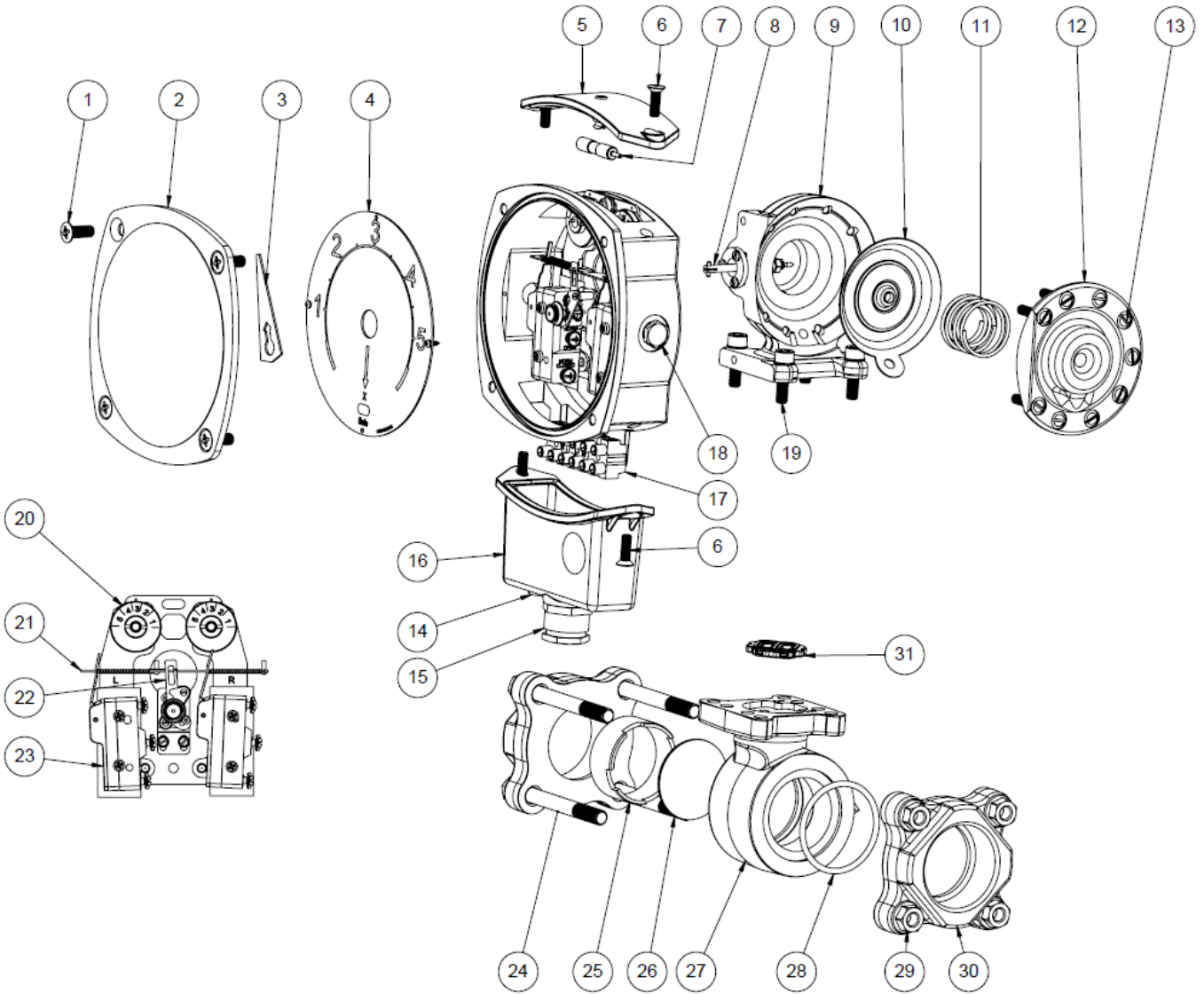

Item	Description	Qty
1	Screw	4
2	Dial glass	1
3	Pointer	1
4	Dial	1
5	Cover	1
6	Screw	4
7	Tool	1
8	Lever / rubber seal	1
9	Diaphragm housing	1
10	Diaphragm	1
11	Diaphragm spring	1
12	Diaphragm cover	1
13	Screw and washer	6
14	Fitting (Ventilation)	1
15	Cable gland Pg16	1
16	Connection box	1
17	Terminal block	1
18	Fitting	2
19	Screw	2
20	Adjusting dail	2
21	Spring bar	1
22	Pointer mechanism	1
23	Microswitch	2
24	Screw	4
25	Spacer GL	1
26	Orifice plate GL	1
27	Pipe body GL	1
28	O-ring	3
29	Nut	4
30	Threaded Flange GL	2
31	Flow direction selector	1

6.5 TIVG-S25F

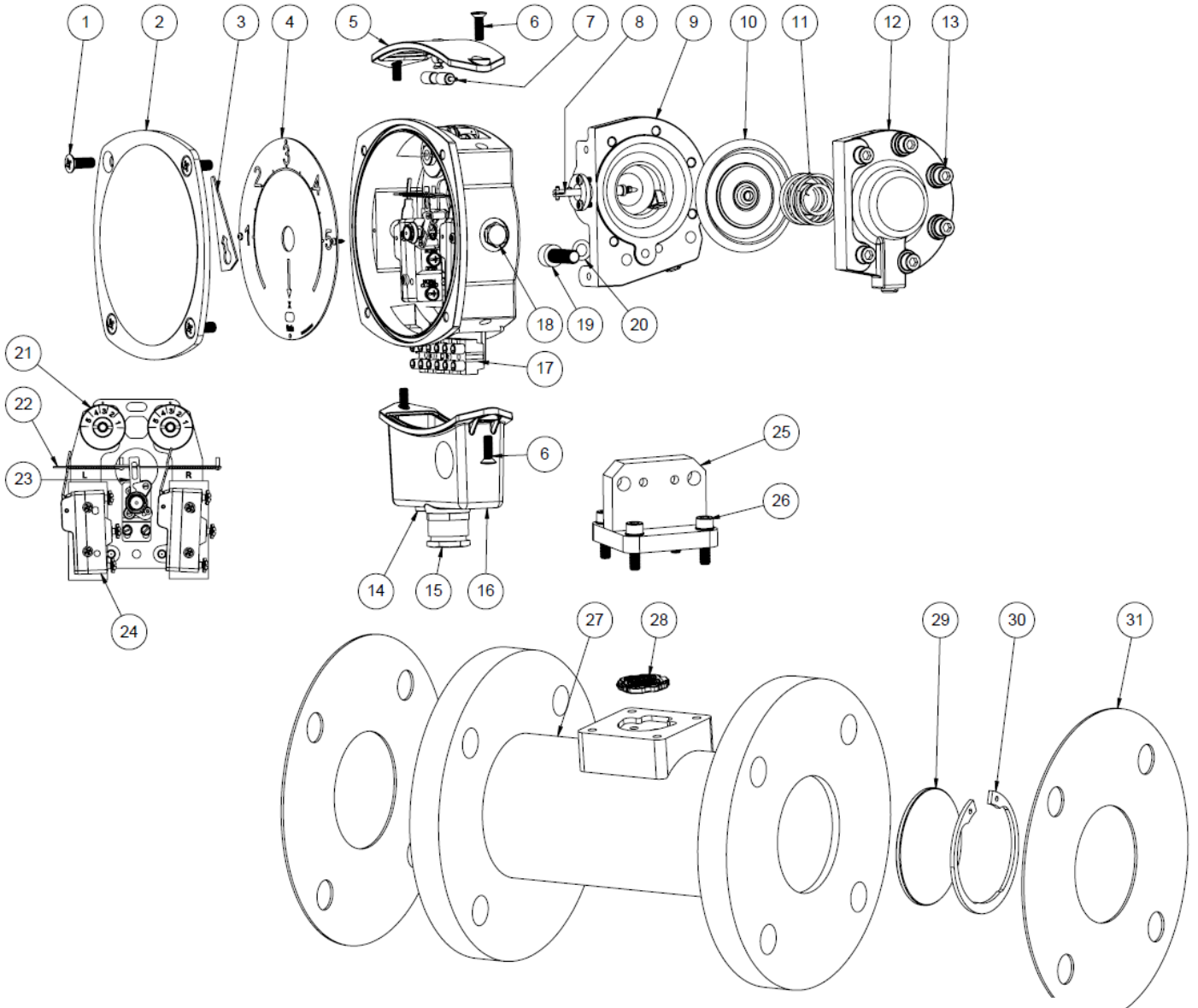

Item	Description	Qty
1	Screw	4
2	Dial glass	1
3	Pointer	1
4	Dial	1
5	Cover	1
6	Screw	4
7	Tool	1
8	Lever / rubber seal	1
9	Diaphragm housing	1
10	Diaphragm	1
11	Diaphragm spring	1
12	Diaphragm cover	1
13	Screw and washer	6
14	Fitting (Ventilation)	1
15	Cable gland Pg16	1
16	Connection box	1
17	Terminal block	1
18	Fitting	2
19	Screw	2
20	O-ring	2
21	Adjusting dial	2
22	Spring bar	1
23	Pointer mechanism	1
24	Microswitch	2
25	Mouting bracket	1
26	Screw	4
27	Pipe TIVG-S25...R	1
28	Flow direction selector	1
29	Orifice	1
30	Locking ring	1
31	Gasket	2

Distributors

Eletta has appointed distributors around the world. You find more information about which distributor to contact on our website www.eletta.com

Recycling

Recycle your product and packaging at disposal



These products and packaging should not be mixed with general household waste. For proper recycling, please take these products to a designated collection point where they will be accepted free of charge.

Please contact your local authority or your household waste disposal service for further details of your nearest designated collection point.

Correct product disposal saves resources and prevents negative effects on human health and the environment.



FLOW MONITORS